



Ministry of Commerce, Industry and Labour
Matagaluega o Pisinisi, Alamanuia ma Leipa



Occupational Safety and Health Guide

Managing the Risk of Falls at Height in the Workplace



ACKNOWLEDGEMENT

In the ongoing efforts of the Government of Samoa through the Ministry of Commerce Industry and Labour ('MCIL') and the Samoa National Occupational Safety and Health Taskforce ('NOSH') to raise the profile of Occupational Safety and Health ('OSH') nationally, this Guideline was developed to support the business community in particularly employers and employees in complying with requirements of OSH Legislation.

In that regard, MCIL would like to recognise and acknowledge the financial support of the Government of Australia through the Samoa Governance Support Program who have made this project become a reality.

We also would like to acknowledge the work of Ms Lydia Richards (MAHRI, M. Education, LLB, GD Legal Practice, GD Conflict Management, GD Business (Admin Mgt), GD OHS Management, GD Education (Digital Technologies) who was our Technical Advisor throughout this assignment. In addition, the consensus and approval of the Samoa National Tripartite Forum who are the lead of all labour matters in Samoa seeing the criticality of prioritising OSH especially now with a global pandemic.

Last but not the least, the following key stakeholders who have been involved in the development of this Guideline and have contributed immensely their time, feedback and advice on the compilation of this document.

Government Representatives;

- Radio 2AP (MCIT)

Private Sector Representatives:

- Craig Construction
- Vodafone Samoa
- Samoa Beverage Co Ltd
- Digicel Samoa
- Samoa Breweries Ltd
- Ah Liki Construction

This Guide was developed using guidance from both the Australian Model Code of Practice for Managing the risk of falls at height in the workplace and the New Zealand Code of Practice for Managing the risk of falls at height in the workplace contextualised to suit Samoa.

Disclaimer:

- *MCIL has made every effort to ensure that the information in this Guide is reliable but makes no guarantee as to its completeness.*
- *Note this guide may be changed at any time without notice.*

Contents

Key Definitions	5
1.0 Introduction7.....	7
1.1 What kind of impact do falls from height, and subsequent injuries, have in workplaces?	7
1.2 Who has safety and health obligations to employees and workplaces? Employers and Designers, Manufacturers and Suppliers	7
2.0 Step One of the Hazard Management Process- Identify Hazards:.....	7
2.1 Typical hazards arising from falls from heights.....	10
2.2 Methods for identifying risks in the workplace-Employers: Step 1 how to identify risks of falls 10	
2.2.1 Inspect the workplace	10
2.2.2 Review available information	11
3.0 Step 2 of the Hazard Management Process- Assess the risk of falls	12
3.1 Planning a risk assessment, including a safe work methods statement	12
4.0 Step 3 of the Hazard Management Process Determine Suitable Controls	13
4.1 Reasonably practicable and the hierarchy of control	14
4.2 Combining control measures	15
5.0 Methods to eliminate or minimise risks from falls from heights.....	16
Fragile Roof Material, Skylights.....	16
5.1 Elimination- Work on ground , where reasonably practicable	17
5.2 Isolation- Work on a solid construction	18
Prevention of falls	18
Safe means of access	19
Fences, handrails.....	19
5.3 Safe access and egress to the elevated workplace	20
5.4 Risk Minimisation.....	20
Fall prevention (restraint) devices- prevents a fall in the first place	20
Temporary work platforms	20
Building maintenance unit, a work positioning system	21
Training, supervision and assistance by competent person when using a fall arrest device	21
Scaffolding, as a temporary work platform	22
Mobile Scaffolds.....	23
Elevating work platforms (EWPs).....	25
Work boxes and work platforms.....	26
5.6 Work positioning systems	26
Safety harness, restraints.....	27
Restraint techniques	27
Industrial rope access systems.....	28

5.7 Fall arrest system-reduces the fall but do not stop it	29
Catch platforms- Group control	29
Safety nets- Group control.....	29
5.7.1 Individual fall arrest systems.....	30
6.0 Emergency Preparedness for fall arrest systems.....	30
Ensuring prompt rescue in event of fall.....	30
7.0 Ladders.....	31
Ladders.....	31
Portable ladders.....	31
Selecting ladders	31
Using ladders safely	32
Fixed ladders	34
Ladder maintenance	34
8.0 Information, training, instruction and supervision.....	35
9.0 Administrative controls.....	35
9.1 No go areas	35
9.2 Permit systems.....	36
9.3 Organising and sequencing of work.....	36
10.0 Emergency procedures for falls	36
10.2 Suspension intolerance.....	37
10.3 Preventing suspension intolerance.....	37
10.4 Training for rescues.....	38
11.0 Steps 4 and 5 of the Hazard Management Process implement, monitor and review.....	38
12.0 Designer, manufacturer and supplier obligations for eliminating or minimising the risk of falls at the design stage.....	38
12.1 Design of workplaces	39
12.2 Design of plant	40
WORK AT HEIGHTS SELF-ASSESSMENT CHECKLIST, example	41
Appendix B Working at heights safe work method statement (SWMS) template (example Qld Govt, Dept education)	45
Appendix C—References and other information sources	47
Appendix D, Hazards and Control Combination Examples	48
Appendix E High risk work licences (for working at height) and classes of high risk work.....	50
High risk work licences—competency requirements	53
Purpose of this Schedule.....	53

Key Definitions

Anchorage: means a secure point for attaching a lanyard, lifeline or other component of a travel restraint system or fall-arrest system. Anchorages require specific load and impact capacities for their intended use

Best Practice Approach: refers to suggested actions which currently go beyond specific legal obligations pursuant to the Occupational Safety and Health Act, 2002 and the Occupational Safety and Health Regulations, 2017

Commissioner: means the Commissioner of Labour, or a person lawfully acting in the role of the Commissioner

Competent Person: In most jurisdiction's competency to perform many tasks at height requires the person to have a 'licence'. Eligibility for licenses is based on that person having obtained a certified qualification after achieving competencies in an approved training package. For the purposes of this Guide, best practice determines that acceptable competency is based on a license for specified work obtained either in Australia, New Zealand or other jurisdiction, as approved by the Commissioner (a recognised international jurisdiction). Appendix E provides a schedule of specified work and the respective licensing requirements for that work. This Guide uses this icon identify areas where competency by way of licensing is required. 

Identified International Standard: Due to the significant risks of falls from height there are many International Standards (eg AS/NZ, British, or ISO) ranging from the safe use of ladders, scaffolds through to personal fall arrest systems. The key international standards for working at heights are described in Appendix C. Employers are expected to ensure that working at height tasks are performed in accordance with the relevant international standard(s), including those identified in this Guide.

Recognised international jurisdiction: for the purposes of determining competency a person granted a license to undertake the specified task from either Australia, New Zealand or another jurisdiction approved by the Commissioner.

Reasonably practicable: A requirement upon duty holders to do what they are reasonably able to do. It requires the duty holder to decide is it REASONABLE in the circumstances to do ALL that is possible or given the circumstances is it REASONABLE to do LESS based on consideration of

- a) the likelihood of the hazard or the risk concerned occurring
- b) the degree of harm that might result from the hazard or the risk
- c) what the person concerned knows, or ought reasonably to know, about the hazard or risk, and ways of eliminating or minimising the risk
- d) the availability and suitability of ways to eliminate or minimise the risk, and
- e) after assessing the extent of the risk and the available ways of eliminating or minimising the risk, the cost associated with available ways of eliminating or minimising the risk, including whether the cost is grossly disproportionate to the risk.

Safe work method statement: for high risk work as part of the risk assessment and control process a 'safe work method statement' must be developed to ensure that all activities are planned and suitably controlled. An example is in Appendix B.

Transition Period: A specified period of time in which duty holders are given time to ensure compliance with the law, during which the law will not be enforced with any deterrent penalty. The transitional period is 1st January 2022

Scope and Aim of this Guide

This guide is intended for duty holders under the Occupational Safety and Health Act, 2002 (the OSH Act) and Occupational Safety and Health Regulations, 2017 (the OSH Regulations) and provides guidance on what is required to comply with their duties under this legislation.

In addition, this Guide provides supplemental information of a **'best practice approach'** for the management of risks associated of falls in Samoan workplaces. Although the best practice approach **may go beyond a strictly legal obligation**, duty holders are **encouraged to work towards best practice**. It is anticipated that future regulatory changes to Samoan OSH law will reflect aspects of the 'best practice approach' found in this Guide.

This guide provides information and advice to both employers, and, as the elimination or minimisation of falls can best be achieved in the design or manufacturing stage it also provides information and advice to manufacturers, designers and suppliers.

To identify which are **current legal obligations**, compared to those which are **suggested best practice**, the following symbols are used.

*Denoted with the symbol:



current mandatory legal obligations, duty holder must ensure they comply



recommended best practice approach, a recommended approach

Note this is a generic guide, not industry specific, other industry guides that control industry specific issues should also be considered when identifying, assessing and controlling risks of working at height. This Guide in no way reduces or removes any requirement under existing law for a licence or other experience or qualifications

Exclusions

The focus on this information Guide is on the hazard of **falls from height** in the workplace.

Slipping and tripping (on the same level) are hazards which also exist at workplaces and may also cause serious injury. It should be noted that employers have a legal duty with regards to falls on the same level, however, the focus on this Guide is on **falls from one level to another**.

Commons falls on the **same level** arise from:

- the type and stability of the floor or ground surfaces such as uneven or broken concrete and sloping ground
- slippery floor surfaces caused by water, fluid spillage and oil
- equipment, boxes and materials blocking walkways
- carrying things that obscure the view ahead
- poor lighting
- inadequate or improper footwear

1.0 Introduction

This guide provides information on how to ensure compliance with the current Samoan law regarding managing the:

- **employer's duty** to ensure employees and the workplace are free, **so far as is reasonably practicable**, from risks to safety and health associated with falls from height; as well as the
- duties of **designers, manufacturers and suppliers** regarding falls from height.

Falls can occur from one level to another level (height) or on the same level. The focus of this Guide is on falls from one level to another (height). All references to falls in this Guide are falls from one level to another.

1.1 What kind of impact do falls from height, and subsequent injuries, have in workplaces?

Fall hazards are found in many workplaces where work is carried out at height, for example stacking shelves in warehouses and retail outlets, working on a roof, unloading a large truck or accessing silos. Falls can also occur at ground level into holes, for example trenches or service pits.

Falls can lead to serious consequences including fatalities.

1.2 Who has safety and health obligations to employees and workplaces? Employers and Designers, Manufacturers and Suppliers

Under both the OSH Act and OSH Regulations **employers, as well as designers, manufacturers and suppliers** have **legal obligations** surrounding the management, and in particular, where reasonably practical or reasonable, the elimination or minimisation of risk, from falls at workplaces.

OSH Act Part 3 General Duties of Care, Section 11



General duty of employers to employees

An employer must take all reasonably practicable steps to protect the safety, health and welfare, at work of employees and to provide and maintain a safe and healthy work environment including; substances, systems of work, and, any building or public or private area in which work takes place.



Current law requires the employer to take '**reasonably practicable**' steps to protect the safety, health and welfare of employees, in the context of falls this includes developing safe systems of work (e.g. the design and organisation of tasks and work processes including safe operating procedures and training). The employer's decision on what is 'reasonably practical' is discussed in 4.1, hazard control.

2.0 Step One of the Hazard Management Process- Identify Hazards:

The hazard management process is a five step approach to managing risk in the workplace for legal compliance.

Figure A, below outlines the steps for legal compliance, namely:

- **identify** which workers are at risk of injury due to falls,
- determine which **tasks or situations** could cause workers harm due to falls
- evaluate the hazards, **assess the risk**
- identify and decide what kind of **control measures** should be implemented,
- implement
- **record, monitor and review** to check the effectiveness of the existing control measures.

Note that penalties may apply if this process is not undertaken.

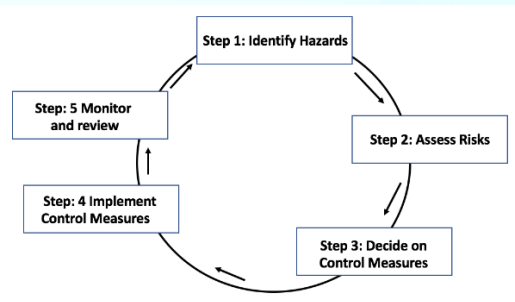

Figure A hazard management process steps



OSH Act Part 3 General Duties of Care, Section 12

An employer must establish and maintain effective methods for:

- a) systematically identifying existing and potential hazards to employees:
- b) systematically identifying at the earliest practicable time, new hazards to employees,
- c) regularly assessing the extent to which a hazard poses a risk to employees

(2) The methods may include but not necessarily be limited to self-inspection and hazard identification process approved by the Commissioner and notified or published in the Savali, and shall be carried out in cooperation with workplace representatives and Committees...



OSH Regulations Part 11 Regulation 3 Hazards and Risk Assessments

(3) Hazard identification and risk assessment

1. An employer must ensure that appropriate steps are taken to identify all reasonably foreseeable hazards arising from work which may affect the health or safety of employees or other persons in the workplace
2. If a hazard is identified under sub regulation (1), an employer must ensure that an assessment is made of the risk associated with the hazard
3. In carrying out an assessment under sub regulation (2) an employer must, as far as reasonably practicable, determine a method of assessment that adequately addresses the hazard identified, including one or more of the following:
 - a) a visual inspection
 - b) auditing
 - c) testing
 - d) technical or scientific evaluation
 - e) an analysis of injury or near miss data;
 - f) discussions with designers, manufacturers, suppliers, employees or other relevant parties
 - g) a quantitative analysis
4. Without limiting sub regulations (1) and (2) the identification of hazards and the assessment of associated risks must be undertaken:

before the introduction of any plant or substance;

or

before the introduction of a work practice or procedure; or

before changing the workplace, a work or work practice, or an activity or process, where to do so may give risk to a risk to health or safety.

5. An employer who contravenes this regulation commits an offence and is liable on conviction:

- (a) For a corporation, to a fine not exceeding 1000 penalty units; and
- (b) For any other case, 100 penalty units.



It is also a legal requirement that the inspection and risk assessment process should be carried out with the **co-operation of workplace safety and health representatives and committees**.



Even if a workplace does not have safety and health representatives or committees it is reasonably practicable to **consult with employees** as well as undertake visual inspections when identifying and assessing falling hazards.



OSH Act 21 Accident notification and investigation

- (1) Where there occurs in or about an employer's place of work an accident that causes death or serious injury or illness to a person, the employer shall:
 - (a) notify the Commissioner as soon as possible; and
 - (b) give written notice of occurrence within 7 days the.



Current law requires an employer to notify the Commissioner should an accident or incident occur.



Regulation 81 Notification of Serious Accidents

Subject to these Regulations, if a serious accident occurs at a workplace, the person-in-charge of the workplace must give notice of the accident as follows:

- (a) the person must give preliminary notice of the serious accident by contacting as soon as practicable after it occurs; and
- (b) the person must give written notice of the serious accident by sending to the office of the Commissioner a prescribed notice within 24 hours.

(1) A serious accident (whether an injury occurs) includes;

- a) The collapse, overturning or failure of the load-bearing part of a scaffold, lift, crane, hoist or mine-winding equipment
- b) Damage to or malfunction of other major plant
- c) The unintended collapse or failure of an excavation that is more than 1.5 m deep, or of any shoring
- d) The unintended collapse or partial collapse of a building or structure under construction, reconstruction, alteration, repair or demolition; or the floor, wall or ceiling of a building being used as a workplace;
- e) An uncontrolled explosion, fire or escape of any gas, hazardous substance or steam;
- f) The unintended ignition or explosion of an explosive;
- g) An electrical short circuit, malfunction or explosion
- h) An unintended event involving a flood of water, rock burst, rock fall or any collapse of the ground;
- i) An incident where breathing apparatus intended to permit the user to breathe independently of the surrounding atmosphere malfunctions in such a way that the wearer is deprived of breathing air or exposed to an atmospheric contaminant to an extent that may endanger health;
- j) Any other intended or uncontrolled incident or event arising from operations carried on at a workplace



Current law requires employers to notify the Commissioner, as soon as practicable after the occurrence of the injury or illness or a serious accident regarding aspects of plant or people at height.

2.1 Typical hazards arising from falls from heights

The first step in the risk management process is to identify all fall hazards in the workplace. This involves finding things and situations which could potentially cause harm to people. Hazards generally arise from the following aspects of work and their interaction:

- physical work environment
- equipment, materials and substances used
- work tasks and how they are performed, and
- work design and management.



Current law requires an employer to **identify** all locations and work tasks that are reasonably likely to cause injury due to a fall. This includes entry (access) to and exit (egress) from the areas where work is to be carried out.

Factors which contribute to injuries sustained when working at height include:

- Lack of adequate planning and hazard assessment
- Inadequate supervision
- Insufficient training
- Incorrect protection and equipment or use of equipment

2.2 Methods for identifying risks in the workplace: Step 1 how to identify risks of falls

2.2.1 Inspect the workplace

Hazards may be identified by looking at the workplace and how work is carried out.

Walk around the workplace and consult with workers to find out where work is carried out that could result in falls. A checklist may be useful in this process; **Appendix A** provides a **basic checklist of potential fall hazards**. Key things to look for include:

- edges—requiring protection for open edges of floors, working platforms, walkways, walls or roofs
- holes, openings or excavations—requiring guarding
- surfaces, including:
 - surface stability, fragility or brittleness
 - surface strength or capability to support loads
 - the potential to slip, for example where surfaces are wet, polished or glazed
 - the safe movement of workers where surfaces change, and
 - the slope of work surfaces.
- levels—where levels change and workers may be exposed to a fall from one level to another
- structures—the stability of temporary or permanent structures
- the ground—the evenness and stability of the ground for safe support of a scaffold or work platform
- the working area—whether it is crowded or cluttered
- safe means of access to and exit from the workplace and working area, and
- hand grip—places where hand grip may be lost.

Particular attention should also be given to work tasks that are carried out:

- near an unprotected open edge, for example near incomplete stairwells or leading formwork edges
- using equipment to work at the elevated level, for example when using elevating work platforms (EWPs) or portable ladders
- on any structure or plant being constructed or installed, demolished or dismantled, inspected, tested, repaired or cleaned
- on or alongside a fragile surface, for example cement sheeting roofs, rusty metal roofs, fibreglass sheeting roofs and skylights
- on a potentially unstable surface, for example areas where there is potential for ground collapse
- on a sloping or slippery surface where it is difficult for people to maintain their balance, such as on glazed tiles or wet surfaces, and
- near a hole, shaft or pit into which a worker could fall such as trenches, lift shafts, service pits or floor and column penetrations.

Other Activity

Employers may also need to talk to manufacturers, designers or suppliers or health and safety specialists. In some situations, employers may need to seek advice from technical specialists like structural engineers to check the stability or load-bearing capacity of structures.

2.2.2 Review available information



OSH Act section 20- Accident Register

- (1) An employer shall keep a register containing details of every accident or incident which causes or which nearly causes death, serious injury or illness to a person whether employed at that workplace or not.
- (2) The register shall comprise copies of all accident report forms and all accident investigation sheets as approved by the Commissioner and notified and published in the Savali.



Current law requires employers to **keep a register of all accidents or incidents**.

Records of previous workplace incidents (injuries and near misses) and worker complaints related to falls should also be checked.

Manufacturers and suppliers can also provide information about hazards and safety precautions for specific plant or processes (information manuals).

3.0 Step 2 of the Hazard Management Process- Assess the risk of falls

A risk assessment involves considering what could happen if someone is exposed to a hazard (**consequence**) and the **likelihood** of it happening. A risk assessment can help determine:

- how severe a risk is
- whether any existing control measures are effective
- what action you should take to control the risk, and
- how urgently the action needs to be taken.

Hazards have the potential to cause different types and severities of harm, ranging from minor discomfort to a serious injury or death.

In some circumstances, a risk assessment will assist to:

- identify which **workers are at risk** of exposure
- determine **what sources and processes** are causing the risk
- identify if and what kind of control measures should be implemented, and
- check the effectiveness of existing control measures.

When assessing the risks (likelihood and consequences) of each fall hazard the following should be considered:

- What could happen if a fall did occur and how likely it is to happen?
- The design and layout of elevated work areas including the distance of a potential fall.
- The number and movement of people at the workplace.
- The proximity of workers to unsafe areas where loads are placed on elevated working areas, for example loading docks, and where work is to be carried out above people and there is a risk of falling objects.
- The adequacy of inspection and maintenance of plant and equipment, for example scaffolds.
- The adequacy of lighting for clear vision.
- Weather conditions including the presence of rain, wind, extreme heat or cold which can cause slippery or unstable conditions.
- The suitability of footwear and clothing for the conditions.
- The suitability and condition of ladders including where and how they are being used.
- The adequacy of current knowledge and training to carry out work safely, for example young, new or inexperienced workers may be unfamiliar with the work.
- The adequacy of procedures for potential emergency situations—including effective procedures for response and evacuation, the provision of medical treatment and assistance (for example ensuring there is appropriate first aid onsite at all times so that first aid is provided immediately and ambulances are called for when necessary), and effective communication.
- The adequacy of current testing and training of the emergency procedures.

3.1 Planning a risk assessment, including a safe work methods statement

Generic risk assessment

If an employer is responsible for a number of different work areas or workplaces and the fall hazards are the same, it may be reasonable to complete a single—or generic—risk assessment. However, a generic risk assessment must be reviewed if there is any likelihood a person may be exposed to greater, additional or different risks at the specific work area or workplace.

Specific activity risk assessment- requirement of Safe Work Method statement

When an irregular or high risk is being undertaken (eg: maintenance, installation, construction) a more intensive and detailed risk assessment should be completed, this will involve a safe work method statement (a SWMS) which is based on the controls discussed below. An example SWMS is available in Appendix B.

4.0 Step 3 of the Hazard Management Process Determine Suitable Controls

After the risk has been assessed a decision about **suitable controls** is required based on consideration of **'what is reasonably practicable'** in the circumstances.

OSH Act Part 3 General Duties of Care, Section 11



General duty of employers to employees

An employer must take *all reasonably practicable steps* to protect the safety, health and welfare, at work of employees and to provide and maintain a safe and healthy work environment including; substances, systems of work, and any building or public or private area in which work takes place.



OSH Act Part 3 General Duties of Care, section 13

Management of identified hazards

- (1) An employer must take appropriate steps to control hazards which are identified and assessed as posing a threat to the safety, health or welfare of employees, and where practical the hazard must be eliminated.
- (2) If elimination is impracticable then steps must be taken to isolate hazards from employees
- (3) If elimination or isolation is impracticable, then employers must take steps:
 - a) To minimise the likelihood that the hazard will be a cause or source of harm to the employees; and
 - b) To ensure that protective clothing and gear is provided, such as meets the standards outlined in this Act, including Codes of Practice and regulations issued by this Act; and
 - c) To monitor the exposure of employees to the hazard; and
 - d) To monitor with the employees informed consent, the health of employees in relation to exposure of the hazard
- (4) The steps taken under this section include action to protect the environment, and persons in the environment from emissions, leakage or spillage from any machine process or substance used or stored in the course of the employer's business or operations.

Regulations 5 Control of Risk

- (5) Control of risks (1) An employer must on the basis of a risk assessment under regulation (2) ensure that any risk to health and safety arising out of work are eliminated or if that is not reasonably practical minimised.
 - (2) An employer must, in the implementation of sub regulation (1) ensure that the minimisation of any risk is achieved by the application of the following hierarchy of control measures
 - a) Firstly, the application, so far as is reasonably practicable, of engineering controls, including substitution, isolation, modifications to design, guarding and mechanical ventilation

- b) Secondly, if steps taken under paragraph (a) do not minimise the risk, the application, so far as is reasonably practical of administrative control. Including safe work practices
- c) Thirdly if steps taken under paragraph (a) and (b) do not minimise the risk, the provision of appropriate protective equipment,
- (3) An employer who contravenes this regulation commits an offence and is liable on conviction:
 - (a) for a corporation, to a fine not exceeding 1000 penalty units: and
 - (b) for any other case, to a fine not exceeding 100 penalty units.

Note failure to comply may lead to a penalty.

4.1 Reasonably practicable and the hierarchy of control



Current law requires the employer to take 'reasonably practicable' steps to protect the safety, health and welfare of employees and the work environment. The employer's decision on what is 'reasonably practical'. It requires the duty holder to decide is it REASONABLE in the circumstances to do ALL that is possible or given the circumstances is it REASONABLE to do LESS based on consideration of:

- a. the likelihood of the hazard or the risk concerned occurring,
- b. the degree of harm that might result from the hazard or the risk
- c. what the person concerned knows, or ought reasonably to know, about the hazard or risk, and ways of eliminating or minimising the risk
- d. the availability and suitability of ways to eliminate or minimise the risk, and
- e. after assessing the extent of the risk and the available ways of eliminating or minimising the risk, the cost associated with available ways of eliminating or minimising the risk, including whether the cost is grossly disproportionate to the risk.



The employer must decide what controls are suitable. Note that although the final decision is with the employer, best practice suggests workers and their representatives of workers should be consulted prior to final decision making.



The law requires **elimination** of the risk of falls where **reasonably practicable**, and, where elimination is not practicable, a 'sliding scale' or 'hierarchy' of controls and combination of controls should be used based on what is reasonably practicable. It is a hierarchy because the further from elimination the less effective the controls.

First consider, based on the risk assessment, if it is necessary to eliminate risks so far as is reasonably practicable, then decide on **control measures** and implement—if it is not reasonably practicable to eliminate the risk, implement the most effective control measures that are reasonably practicable in the circumstances in accordance with the hierarchy of control measures, and ensure a plan is in place to **review control measures** to ensure they are working as planned and are not introducing new hazards.

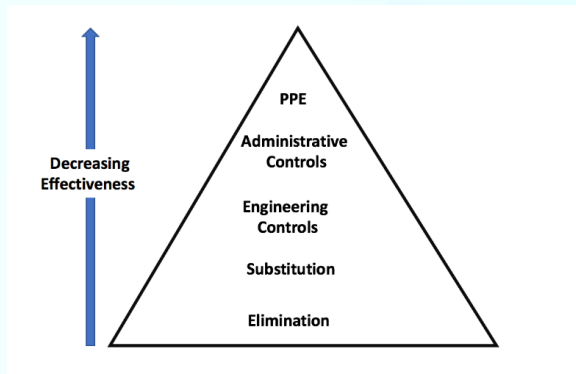

Figure 2 The Hierarchy of control

Eliminating the risk- The aim is to eliminate the risk. If eliminating the hazards and associated risks is not reasonably practicable, minimise the risk by one or more of the following:

Substitution—minimise the risk by substituting or replacing a hazard or hazardous work practice with something that gives rise to a lesser risk.

Isolation—minimise the risk by isolating or separating the hazard or hazardous work practice from any person exposed to it.

Engineering controls—engineering controls are physical control measures to minimise risk. Control measures should be aimed at eliminating or minimising the frequency, magnitude and duration of movements, forces and postures by changing:

If any risk remains, it must be minimised by implementing **administrative controls**, so far as is reasonably practicable. Administrative controls may also be used to support other control measures. However, the exclusive use of administrative controls to minimise the risk of falls is only appropriate when it is not reasonably practicable to use a higher order control.

Any remaining risk must be minimised with suitable **personal protective equipment (PPE)**. In relations to work from heights current Samoan law provides general advice about the use of clothing, for the risk of falls **equipment** is a particular necessity.

OSH Act Part 3 General Duties of Care, section 15

Protective Clothing and Equipment PPE

An employer shall:

- a) provide, maintain and make accessible to employees the protective clothing and equipment necessary to avoid injury and damage to their health; and
- b) take all reasonably practical steps to ensure that the employees use that protective clothing and equipment whenever the circumstances for which it is provided arise; and
- c) make provision in the place of work, for protective clothing and equipment so provided to be cleaned and securely stored without risk of damage when not required.



Current law requires employers to provide appropriate PPE to the employee, however most often PPE is a 'last' resort or necessarily included with other controls as described below.

4.2 Combining control measures

A combination of control measures may be used to minimise risks, so far as is reasonably practicable, if a single control is not sufficient for the purpose. In most cases, a combination of the control measures will provide the best

solution to minimise the risk to the lowest level reasonably practicable. Controls that protect groups of workers 'group controls' provide a higher level of protection than controls for individuals.

Employers should also ensure that the control measures selected do not create new hazards, for example electrical risks from contact with overhead power lines or crushing and entanglement from plant like an elevated work platform. If any new hazards are created they must also be controlled. The following table provides an example of both group and personal control measures from the most effective (desirable) to least desirable, based on so far as is reasonably practicable (New Zealand 2012, Best Practice for working at Height, p. 11).

DESIRABLE ↑ ↓ UNDESIRABLE	ELIMINATE Eliminate the height hazard by avoiding work at height if you can. If you don't need to go up there, don't! For example, by assembly at ground level.		
	WORK EQUIPMENT	GROUP CONTROL MEASURES	PERSONAL CONTROL MEASURES
	ISOLATES the height hazard	edge protection systems, barriers, scaffolding, guardrails, multi user MEWP, safety mesh	total restraint system ¹ , single user MEWP, platform (podium) ladder, mobile guarding system, man cages
	MINIMISES height and the consequence of the height hazard	safety nets at high level, soft landing systems	work positioning systems, industrial rope access, fall arrest system
	MINIMISES the consequence of the height hazard	safety nets at low level (<6m), remote soft landing systems	life jackets, inflating air suits
	MINIMISES through management controls	trestles, hop-up trestles, platforms	ladders, stepladders, stilts

1. A total restraint system prevents the wearer from being exposed to a height hazard. Because a harness is classified as personal protective equipment it is treated as minimisation. In the order of desirability in fall prevention, it features higher than other minimisation methods.

Further, Appendix D provides a table of Hazards and Control Combination examples.

5.0 Methods to eliminate or minimise risks from falls from heights

The following include current specific legal requirements in Samoa as well as providing further guidance and information. The sequence of examples below uses the 'hierarchy of control', from the most effective method to the least and employers should ensure they have made a decision on what method based on 'what is reasonably practicable'.

For all information about recommended controls relevant identified International Standards should also be followed.

Fragile Roof Material, Skylights



OSH Regulations Part 4 Regulation 22

Fragile roofing materials (1) If the whole or any part of the roof of a building or structure that comprises or includes a workplace consists of (or includes) any fragile material, then appropriate steps must be taken to warn persons who may be required to carry out work on the roof.

(2) Appropriate steps under sub regulation (2) may include the display of a sign in both Samoan and English language: (a) that states 'Danger Fragile Roofing – Use Crawl Boards'; or

(b) that advises a person to seek the advice of appropriate personnel before commencing work on the roof.

(3) If a part of the roof of a building or structure that comprises or includes a workplace consists of fragile skylight:

(a) safety wire mesh must be securely fixed immediately above or below the skylight (and in the case of mesh above the skylight, it must be resistant to corrosion); or

(b) barriers securely fixed and adequately maintained must be installed around the skylight.

(4) if work must be carried out on a roof that consist of (or includes any fragile material):

(a) a person performing or assisting with the work must be provided with safe access to the roof;

And

(b) a safe system of work must be provided and maintained in relation to the performance of the work; and

(c) if there is no reasonably practicable alternative to a person working on the roof, a person working on the roof must be provided with (and use) walkways and crawling boards of a suitable size and strength.



Current law requires employers to ensure that visible **warning signs** are provided to workers and others (e.g. visitors, contractors) prior to entering an area with fragile roof material, that skylights be reinforced with **non-corrosive mesh** (see below), or **barricades** and that a system of work (safe procedures) is provided that ensure safe access as well as be provided with a suitable walkway or crawl boards. Below, opening with mesh.

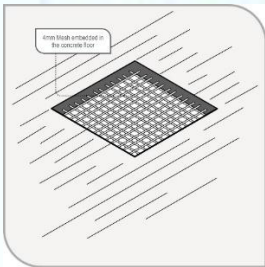

The cover should also include signage indicating its purpose as a cover, for example '**Danger Fragile Roofing – Use Crawl Boards**'



Current Samoan law provides for a **hierarchical approach to controlling the risks of working at heights**. The legislation is detailed below as well as further explanations and guidance.

5.1 Elimination-Work on ground, where reasonably practicable

Eliminating the need to work at height is the most effective way of protecting workers from the risk of falls. The following are examples of tasks that may be carried out on the ground to eliminate the risk of falls are:

- prefabricating roofs at ground level
- prefabricating wall frames horizontally then standing them up
- installing air-conditioning units at ground level
- using mechanical tarp spreaders to cover loads on trucks from the ground
- reducing shelving heights so workers can access items from ground level
- using tools with extendable handles, for example paint rollers—however, the risk of musculoskeletal disorders will need to be considered when deciding whether to use such tools
- lowering a concert hall chandelier to repair it,
- fitting outlets, inlets and controls of large tanks and silos near the ground rather than a height
- using long handled tools

5.2 Isolation-Work on a solid construction

The next best alternative to working on the ground is working on a solid construction as it provides an environment where the likelihood of a fall may be eliminated. 'Solid construction' means an area:

- with a surface that is structurally capable of supporting workers, materials and any other loads applied to it

Access and egress (entry and exit) on a solid construction

The solid construction must have a safe means for people to enter and exit and to move around the work area, for example permanently installed platforms, ramps, stairways or fixed ladders.

Other safety considerations for entrances and exits in a solid construction include:

- exposure of access systems to the weather, for example rain can make surfaces slippery and strong winds can cause loss of hand grip
- providing natural or artificial lighting to access ways, and
- clearing obstructions so people are able to move easily to and from the workplace.

Portable stepladders and trestle ladders should not be used for entries or exits and single or extension ladders should only be used where the use of safer systems is not reasonably practicable

An identified international standard is, *AS 1657–2013: Fixed platforms, walkways, stairways and ladders – Design, construction and installation*.

Surface and gradient of a solid construction

Surfaces of a solid construction should be non-slip, free from trip hazards and should generally not exceed 7 degrees—1 in 8 gradients. Cleated surfaces, which provide greater slip-resistance, should not be steeper than 20 degrees—1 in 3 gradients.

If grid mesh or checker plate flooring is used for walkways and working platforms you should, ensure:

- flooring panels are securely fixed and assembled in accordance with the manufacturer's specifications
- where possible, the flooring is fitted to the structure before being lifted into permanent position
- each panel is fixed securely before the next panel is placed in position
- during installation, this type of flooring is secured by tack welding, panel grips or other means to prevent movement before being fixed permanently, and

if panels of grid mesh or checker plate flooring are removed, edge protection is provided and the gaps left due to removed panels are protected

Prevention of falls



Regulation 54(1) If:

- (a) a person must work-
 - (i) in an elevated workplace from which he or she could fall; or
 - (ii) in the vicinity of an opening through which he or she could fall; or
 - (iii) in any other place from which he or she could fall, and it is reasonably foreseeable that the person would be injured in such fall due to the distance of the fall; or
- (b) a person must work in the vicinity of an enclosure or container into which her or she could fall and there is a reasonable likelihood that the person would be injured in such a fall

reasonable protection against a fall must be provided:

Safe means of access

(aa) by the provision of a safe means of access to the workplace; and

A safe means of access includes fixed stairways or mechanical lift.

Fences, handrails

(bb) by the provision of secure fences, covers or other forms of safeguarding or, if that is not reasonably practicable due to the nature of the work, by the provision and maintenance of safe systems of work.

Isolation barriers to prevent a person falling over edges and into holes must be provided on relevant parts of a solid construction. These include:

- the perimeters of buildings or other structures
- floors, including mezzanine floors—see below

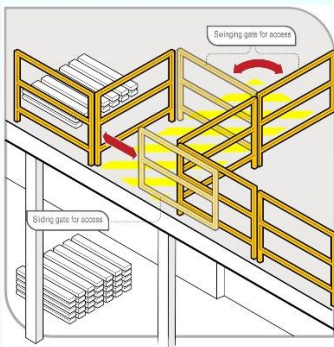

- openings in floors, and
- the open edge of a stair, landing, platform or shaft opening—see below

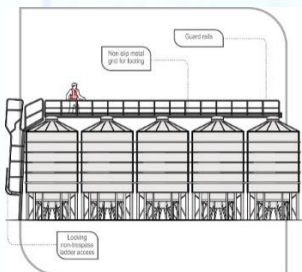

The barrier must be designed and constructed to withstand the force of someone falling against it and sufficiently high.

Toe boards and other material should be used to ensure material is not dropped on workers below.

Identified International Standards include: *AS/NZS 4994 (set): Temporary edge protection*, in particular:

4994.1:2009: Temporary edge protection – General requirements

AS/NZS 4994.2:2009 Temporary edge protection – Roof edge protection – Installation and dismantling

AS/NZS 4994.4:2018: Temporary edge protection – Perimeter protection screens

Protection around holes, penetrations and openings

Where persons are working near and around holes, penetrations and openings through which a person could fall, for example with covers, barricading or by embedded mesh—see below.

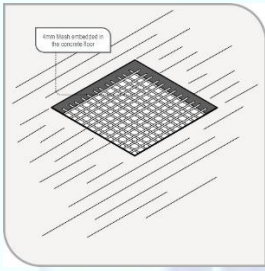

An Identified International Standards includes: *AS/NZS 4389:2015: Roof safety mesh*

If a cover is used as a control measure it must be made of a material strong enough to prevent people or objects falling through and securely fixed.

The cover should also include signage indicating its purpose as a cover, for example 'DANGER HOLE BENEATH'.

5.3 Safe access and egress to the elevated workplace

Regulation 54 (2) If a person at work must gain access to a place that cannot be reached conveniently from floor to ground level, and no appropriate means of mechanical access or fixed stairway is available, a suitable ladder or steps must be provided.

(3) Any safe means of access provided for the purposes of sub regulation (1)(aa) must be kept in good condition and must not be removed except so far as may be necessary to allow the access or exit of any person or the shifting materials.

If there is no lift or fixed stairway a suitable ladder or steps are to be provided. Information and guidance about ladders can be found in section 9.0 of this Guide.

*(note Section 54 (4) is not discussed in this Guide, as, based on the hierarchy of control it is more effective in terms of safety to prevent a fall via temporary work platforms than a fall arrest system- note however that some work platforms, particularly moving platforms include a fall arrest system (harness) as an additional control.

5.4 Risk Minimisation

Where elimination is not reasonably practical the following should be considered.

Fall prevention (restraint) devices- prevents a fall in the first place

A 'fall prevention device' is material or equipment—or a combination of both—designed to **prevent** a fall for temporary work at heights, that once in place after initial installation does not require any ongoing adjustment, alteration or operation by any person. Fall prevention devices include secure fencing, edge protection, working platforms and covers as described above.

Temporary work platforms

A 'temporary work platform' is a working platform, **other than a permanently installed** fixed platform, used to provide a working area for the duration of the work. The design of the platform prevents workers from falling.

Temporary work platforms include:

- building maintenance units,
- scaffolds,
- elevating work platforms (EWPs),
- mast climbers,
- workboxes,
- portable or mobile fabricated platforms or any other platform that provides a working area designed to prevent a fall.

An identified International Standard includes: *AS 2550.16–1997: Cranes – Safe Use – Mast climbing work platforms.*

Regulation 54 (5) Without limiting sub regulation (1), (2), (3) or (4) if:

- (a) a person carries out maintenance work on a structure; and
- (b) the person must work in an elevated workplace;
- (c) it is reasonably foreseeable that the person would be injured if he or she fell due to the distance of the fall

Reasonable protection against any fall must be provided:

Building maintenance unit, a work positioning system

Regulation 54 (5) (aa) by the use of a building maintenance unit installed by a competent person; or

A building maintenance unit is a power-operated suspended working platform that is fixed permanently to a building or structure. It is used for access for building maintenance or window cleaning.

When using a building maintenance unit, you should ensure that:



Accepted international standards for building maintenance units should be followed, e.g.

AS 1418.13–1996: *Cranes (including hoists and winches) – Building maintenance units,*

AS/NZS 1891.1:2007 *Industrial fall-arrest systems and devices- Harnesses and ancillary equipment*

and advice should be sought from a person who **has undergone suitable training** and is considered **competent** to perform the task as well as, these include

- the unit has clearly designated **fall arrest harness anchorage points** designed to withstand the forces caused by a fall of a person located anywhere on the platform
- any person on the platform wears a **fall arrest harness**
- the fall arrest harness is inspected
- helmets are worn
- operators possess a suitable attitude for working at height, including a responsible attitude to safety
- that consideration is given to wind speed before commencing
- that an exclusion zone is set up to protect passers by
- Accepted standards for building maintenance units should be followed, and advice should be sought from a person who has undergone suitable training and is considered competent (licensed) by a recognised international jurisdiction.

Training, supervision and assistance by competent person when using a fall arrest device (safety harness)

In cases where a safety harness is used to arrest a fall the legislation requires:

Regulation 54 (4)

- (c) the undertaking of training in relation to the hazards that may be encountered in the performance of the work;
- (d) the provision of supervision by a competent person;
- (e) the provision of assistance by another person.

Consideration will also need to be considered regarding emergency rescues.

Note for all plant, such as building maintenance units you should also refer to the *Guide on Managing the Risks of Plant* in the workplace which provides advice about following the manufacturers specifications including inspection and maintenance of any unit.

Scaffolding, as a temporary work platform



Note competency requirements apply to erecting, inspecting and certifying scaffolding.

Regulation 54 (5) (bb) by the use of scaffolding or another type of working platform,

Regulation 61 Scaffolds- An employer must, in relation to a scaffold, ensure:

- (a) that no work is carried out from –
 - (i) a suspended scaffold; or
 - (ii) a cantilevered scaffold; or
 - (iii) a spur scaffold; or
 - (iv) a hung scaffold; or
 - (v) any other scaffold,

from which a person or object could fall more than 4 metres, unless that employer has obtained written confirmation from a competent person that the scaffold, or the relevant part or portion of the scaffold, is complete; and

- (b) that a scaffold of a kind listed in paragraph (a) and its supporting structure, is inspected by a competent person for compliance with these Regulations –
 - (i) prior to its first use; and
 - (ii) as soon as practicable, and prior to its use, following an occurrence that can reasonably be expected to affect the stability or adequacy of the scaffold (for example, severe storm conditions or earthquake);
 - (iii) prior to its first use following repairs; and
 - (iv) in any event at intervals not exceeding 30 days; and
- (c) if an inspection of a scaffold or its supporting structure indicates an unsafe condition, that appropriate repairs, alterations and additions (as necessary) are carried out and reinspected by a competent person prior to further use of the scaffold
- (d) if a scaffold is incomplete and left unattended, that appropriate controls (including the use of danger tags or warning signs) are used to protect against unauthorised access to the scaffold.



Current law indicates a person with management or control of a scaffold must not allow the use of a scaffold from which a person or object could fall more than 4 metres **unless a competent person, who has inspected the scaffold, provides written confirmation** that the scaffold has been completed. And that suitable controls are in place to stop unauthorised access.

Identified International Standards include the, *AS/NZS 1576.1 – 6 Scaffolding Series*.

AS/NZS 1576.1:2010: Scaffolding – General requirements

AS/NZS 1576.2:2016: Scaffolding – Couplers and accessories

AS/NZS 1576.3:1995: Prefabricated and tube-and-coupler scaffolding

AS/NZS 1576.4:2013: Scaffolding – Suspended scaffolding

AS/NZS 1576.5:1995: Scaffolding – Prefabricated splitheads and trestles

AS/NZS 1576.6:2000: Scaffolding

AS/NZS 4576:1995: Guidelines for scaffolding

The person with management or control of a scaffold must also ensure that:



the scaffold and its supporting structure are inspected by a **competent person**:

- before use of the scaffold is resumed after an incident occurs that may reasonably be expected to affect the stability of the scaffold (such as a severe storm or impact by mobile plant)
- before use of the scaffold is resumed after any repairs, and
- at least every 30 days.
- if an inspection indicates that a scaffold or its supporting structure creates a risk to health or safety, that any repairs, alterations and additions are made or carried out and the scaffold and its supporting structure are inspected again by a competent person before use is resumed, and
- unauthorised access is prevented on scaffolding that is incomplete and left unattended, for example by attaching danger tags and warning signs at appropriate locations.

These safe load limits include the weight of people plus the weight of any materials, tools and debris on the working platform.



Where work is carried out from a scaffold, **workers must be provided with information, training and instruction** on the nature of the scaffolding work, the risks associated with scaffolding and the control measures implemented to reduce that risk. This may include information, training and instruction on:

- emergency response procedures
- what loads the scaffold can safely take (Safe Working Load (SWL))
- not to make unauthorised alterations to the scaffold, such as removing guardrails, planks, ties, toe-boards and braces
- keeping working platforms clear of debris and obstructions along their length
- never accessing incomplete or defective scaffolds
- immediately reporting defects, if they occur
- isolating electrical leads from the metal frame of the scaffold with plastic lead hooks or an insulated rubber material where reasonably practicable (to prevent damage to the leads or electrifying the scaffold)
- the requirement for a specific risk assessment and control 'statement' referred to as a safe work method statement (SWMS) to be developed for any work carried out at or above 2 metres, and
- complying with any electrical 'permit to work' requirements issued by the electricity supply authority for work conducted from a scaffold that has been erected within the power line 'no go' zone.

Mobile Scaffolds

Mobile scaffolds should not be more than 12 meters.

Where mobile scaffolds are used, workers should be trained in their use, including on how to ensure the scaffold:

- remains level and plumb

- is kept well clear of power lines, open floor edges and penetrations
- is not accessed until the castors are locked to prevent movement
- is not moved while anyone is on it, and
- is accessed using an internal ladder, see below, except for low height platforms where this is not reasonably practicable.

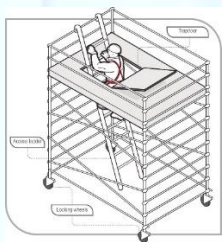

Suspended (swing stage) scaffold

An identified international standard includes: AS/NZS 1891.1:2007 Industrial fall-arrest systems and devices- Harnesses and ancillary equipment

A suspended scaffold incorporates a suspended platform capable of being raised or lowered when in use. Other terms often used are ‘suspended cradle’ and ‘swing stage’ scaffold, see below.

Employer’s must ensure:

- that suitable working load and specifications are met
- workers operating suspended scaffolds are trained in their safe operation
- workers installing or servicing a suspended scaffold must be competent by either:



Competence requires an advanced rigging or advanced scaffolding high risk work licence to build, other requirements include:

- the unit has clearly designated **fall arrest harness anchorage points** designed to withstand the forces caused by a fall of a person located anywhere on the platform
- any person on the platform wears a **fall arrest harness**
- the fall arrest harness is inspected
- helmets are worn
- operators possess a suitable attitude for working at height, including a responsible attitude to safety
- that consideration is given to wind speed before commencing
- that an exclusion zone is set up to protect passers by
- the platform remains horizontal when it moves up or down.

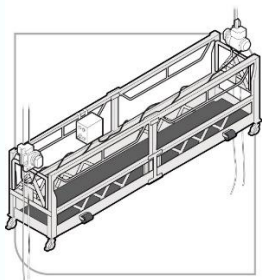



Where workers work on a platform that also requires a fall arrest device Samoan law requires that they are giving adequate training of the risks as well as supervision by a competent person and assistance by another in case a rescue is required.

Elevating work platforms (EWPs)

An identified international standard includes *AS/NZS 1891.1:2007 Industrial fall-arrest systems and devices- Harnesses and ancillary equipment*

EWPs include boom-type EWPs and scissor lifts (see below.) Note that some are designed for hard flat surfaces only while others are designed to be operated on rough terrain. Some types are designed for indoor use and are not suitable for windy conditions outdoors. Employers should check the manufacturer's instructions for use.

If using an EWP at the workplace, employers must identify the hazards associated with the use of the EWP and implement control measures to eliminate or minimise those risks so far as is reasonably practicable. The main hazards related to the use of EWPs are contact with electric lines, overturning the machine, falling from the work platform, and potential crushing hazards when elevating the platform or moving laterally.

Relevant risk control measures when using EWPs should include:

- training and instructing workers in the safe operating procedures for the particular brand and type of EWP, as well as safe work procedures to avoid crushing and electrical hazards
- training and instructing workers in the safe use of fall arrest equipment and emergency rescue procedures
- ensuring the EWP is only used as a working platform and not as a means of entering and exiting a work area unless review of specific guidance in use of EWP's has been considered
- ensuring the EWP is only used on a solid level surface, unless it is designed for use on rough terrain, and
- checking the surface area to make sure there are no penetrations or obstructions that could cause uncontrolled movement or overturning of the EWP.

In addition to the above, employers must ensure:

- where it is not reasonably practicable to use a fall prevention device or a work positioning system to adequately protect against the risk of a fall, workers working in travel towers, boom lifts or cherry pickers wear a properly **anchored fall arrest harness**. The lanyard should be as short as possible and should be attached directly to the designated anchor point on the EWP, not to the handrail (unless the handrail is the manufacturer's specified anchor point), and



workers operating boom-type EWPs with a boom length of 11 metres or more will be considered competent if they hold a boom-type EWP high risk work licence, or are undertaking the role as part of their training for a licence and are being supervised.

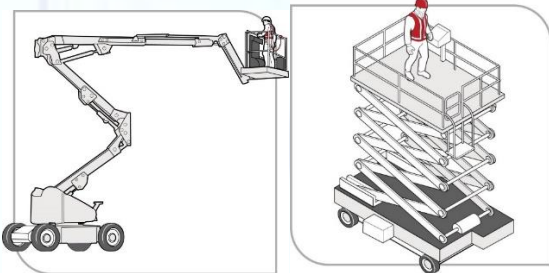

Where reasonably practicable, EWPs or scaffolds are a preferred to the work platforms or workboxes described below.

Work boxes and work platforms

Work platforms are designed to be supported from underneath or the side by forklifts or other mechanical devices. **Work boxes** are designed to be supported from above by a crane, hoist, or other mechanical device. Identified International standards include, AS 1418.17–1996: *Cranes (including hoists and winches) – Design and construction of workboxes*

Both are a platform, surrounded by edge protection, designed to provide an elevated work area for those working in it.

These include ensuring the workbox or work platform:

- is designed for the task and securely attached to the crane, hoist, forklift truck or other mechanical device, and
- is not suspended over people.

Employers should also ensure:

- there is an effective means of communication between any person in the workbox or work platform and the operator
- the operator remains at the controls of the crane, hoist, forklift truck or other mechanical device at all times, and
- lifting attachments and records are checked by a competent person before use.

International standards for workboxes designed to be suspended from cranes should be followed, and advice should be sought from a person who has undergone suitable training and is considered competent at an international level to perform the task.

Work platforms supported by forklifts

Identified International Standards for workboxes designed to be suspended from forklifts should be followed, and advice should be sought from a person who has undergone suitable training and is considered competent at an international level to perform the task.

The work platform should be securely attached to the forklift carriage to prevent it from sliding off the forks.

In managing the risks of using a work platform to provide an elevated work area, employers must ensure that:

- workers are only raised by a forklift when in a compliant work platform
- workers remain within the work platform when it is elevated or being raised or lowered
- no other device such as a ladder or pallet is used to gain additional height (see below) and
- the safety gate is self-closing and kept shut when in the elevated position.

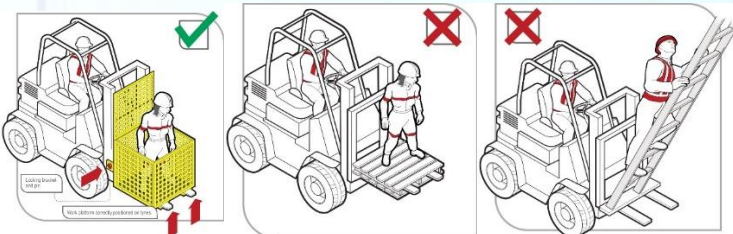

5.6 Work positioning systems

A 'work positioning system' includes any plant or structure, other than a temporary work platform, that enables a person to be positioned and safely supported at a location in such a way that a **fall is prevented**.

The use of work positioning systems must only be considered if it is not reasonably practicable to carry out work on the ground or on a solid construction, or by providing fall prevention devices described above, for example an elevating work platform (EWP).

This Guide has **limited information and guidance on work positioning systems**, in relation to work positioning systems and fall arrest devices reference should be made to International Standards rather than directly following this Guide.

Work positioning systems require a high level of competency on the part of the user and supervisors to ensure safe use. Users, including supervisors, should undertake a relevant competency based course of training before using a work positioning system.

Regulation 54 (4) In determining the appropriate safe system of work for the purposes of sub regulation (1)(bb) consideration must be given to:

(a) if a safe working platform cannot reasonably be provided, the use of a safety harness or a pole safety belt (if appropriate), attached to a secure structural support (either directly or if that is not reasonably practicable, through the use of an adequate static-line system);

(b) the use of a fall-arresting device (where appropriate)

An identified International Standard is *AS/NZS 1891.1:2007 Industrial fall-arrest systems and devices- Harnesses and ancillary equipment*

Safety harness, restraints

Regulation 54 (cc) if compliance with subparagraph (aa) or (bb) is not reasonably practicable, by the use of a safety harness attached to a safety line that is in turn attached to an appropriate anchorage (taking into account in the situation of the work and the construction of the building).

Regulation 54 (6) A safety harness or line supplied or used for the purposes of this regulation must be inspected on a regular basis and a harness or line that shows wear or weakness to an extent that may affect the integrity of the harness or line must not be used.

Regulation 54 (7) An anchorage or system of anchorage must be inspected on a regular basis and, for an anchorage that is permanently fixed to a structure, at least once in every six (6) months.

Regulation 54 (8) If the load-bearing capacity of the anchorage may be impaired, the anchorage must immediately be made inoperable so as to prevent accidental use.

Restraint techniques

A restraint technique controls a person's movement by physically preventing the person from reaching a position at which there is a risk of a fall. It consists of a harness that is connected by a lanyard to an anchorage or horizontal lifeline. It must be set up to prevent the wearer from reaching an unprotected edge—see below.

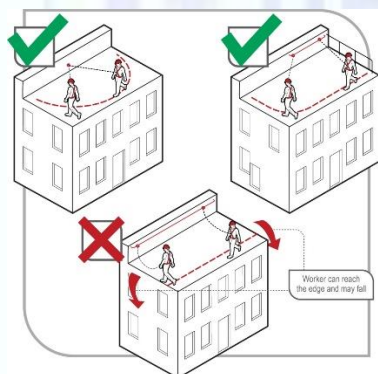

Restraint techniques must only be used if it is not reasonably practicable to prevent falls by carrying out work on the ground or on a solid construction, or by minimising the risk using a fall prevention device, such as providing a physical barrier, for example a guardrail.



A restraint system should be installed by a competent person in accordance with the manufacturer's instructions. Restraint anchorage should be designed for fall arrest loading.

A purpose-designed roof anchor, when used in accordance with the designer's or manufacturer's/supplier's instructions, may be used as part of the restraint technique on metal deck or tiled roofs.

Situations where it may not be reasonably practicable to use a restraint technique include when:

- The user can reach a position where a fall is possible.
- The user has a restraint line that can be adjusted in length so that a free fall position can be reached.
- There is a danger the user may fall through the surface, for example fragile roofing material.
- The slope is over 15 degrees.
- There is any other reasonably likely use or misuse of the system that could lead to a free fall.

In these circumstances it may be more appropriate to use an individual fall arrest system.

Industrial rope access systems

Identified International Standards include

AS/NZS 4488 (set): Industrial rope access systems including:

- *AS/NZS 4488.1:1997: Industrial rope access systems – Specifications*
- *AS/NZS 4488.1:1997/Amdt 1:1999: Industrial rope access systems – Specifications*
- *AS/NZS 4488.2:1997: Industrial rope access systems – Selection, use and maintenance*

Industrial rope access systems are used for gaining access to and working at a workplace, usually by means of vertically suspended ropes. Although fall arrest components are used in the industrial rope access system, the main purpose of the system is to gain access to a work area rather than to provide backup fall protection.

Other methods of accessing a workplace, for example EWPs or building maintenance units, must be considered **before** industrial rope access systems.

Before using an industrial rope access system, a risk assessment should be carried out that, which considers the location of the work and any associated special features of the structure, anchor points, emergency access and weather conditions. A safe work method system statement (Appendix B) should be undertaken.

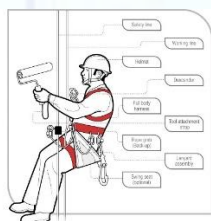

This Guide does not provide detailed information about industrial rope access and further information should be obtained

5.7 Fall arrest system-reduces the fall but do not stop it

Fall arrest systems, such as catch platforms, safety nets and individual fall arrest systems (including anchorage lines or rails), are intended to **safely stop a worker falling an uncontrolled distance and reduce the impact of the fall. These systems must only be used if it is not reasonably practicable to use a fall prevention device or work positioning system** or if these higher level controls might not be fully effective in preventing a fall on their own.

When using fall arrest systems, the following key safety measures should be observed:

- Fall arrest equipment is selected, installed and used correctly. Workers should be trained in the use of fall arrest equipment.
- The equipment and anchorages are designed, manufactured and installed to be capable of withstanding the force applied to them as a result of a person's fall.
- The system is designed and installed so that the person travels the shortest possible distance before having the fall stopped

Identified International Standards include:

AS/NZS 1891.1:2007: *Industrial fall-arrest systems and devices – Harnesses and ancillary equipment*

AS/NZS 1891.2 Supp 1:2001: *Industrial fall-arrest systems and devices – Horizontal lifeline and rail systems – Prescribed configurations for horizontal lifelines*

AS/NZS 1891.3:1997: *Industrial fall-arrest systems and devices – Fall-arrest devices*

AS/NZS 1891.4:2009: *Industrial fall-arrest systems and devices – Selection, use and maintenance*

Catch platforms- Group control

A catch platform is a temporary platform located below a work area to catch a worker in a fall. The platform should be of robust construction and designed to withstand the maximum potential impact load. Scaffolding components may be used to construct fixed and mobile catch platforms.



Competency requires installers of such systems must have an intermediate or advanced scaffolding license (in an identified jurisdiction) or be under the supervision of a person with such license.

Safety nets- Group control

Safety nets can provide a satisfactory means of protection while allowing workers maximum freedom of movement. They should not be used to enter or exit a work area or as a working platform.



Safety nets used in conjunction with basic rigging or scaffolding work must be erected and serviced by competent people, holding a Basic Rigging or Basic Scaffolding license in an identified jurisdiction

When safety nets are used they should be:

- constructed of material strong enough to catch a falling person or thing
- securely anchored before work starts

- hung as close as is practicable to the underside of the working area, but no more than 2 metres below the working area
- sufficiently tensioned and have clearance to prevent a falling person contacting any surface or structure below the net
- inspected, particularly after installation, relocation or repair, and
- stored correctly in dry, shaded areas with good air circulation.

Other precautions when using safety nets include:

- no hot work like welding, oxy cutting, or any other work that may damage the safety net, should be performed above safety nets, and
- material and other refuse should not be allowed to accumulate in safety nets.

5.7.1 Individual fall arrest systems

This Guide does not give specific information about individual fall arrest systems.

Equipment used for individual fall arrest systems should be designed, manufactured, selected and used in compliance with accepted **international standards**.

Individual fall arrest systems must only be used where it is not reasonably practicable to use higher level control measures.



All harness work requires competency.

Individual fall arrest systems rely on workers wearing and using them correctly, therefore workers who will use such a system must be trained in its safe use. Users of individual fall arrest systems should possess a suitable attitude for working at height, including a responsible attitude to safety.

Workers using a fall arrest system should wear appropriate head protection to protect them in a fall.

If the equipment has been used to arrest a fall, it should not be used again until it has been inspected and certified by a competent person as safe to use. There are extensive requirements for industrial fall arrest systems not provided in this Guide. Employers should seek further information from International Standards such as, *AS/NZS 1891 (set): Industrial fall-arrest systems and devices (details above)*.

6.0 Emergency Preparedness for fall arrest systems

Ensuring prompt rescue in event of fall

A fall arrest system requires the establishment of emergency and rescue procedures. The emergency and rescue procedures must be tested to ensure that they are effective, and workers must be provided with suitable and adequate information, training and instruction in relation to the emergency procedures.

The rescue of a worker who is suspended in a full body harness should occur promptly to prevent suspension intolerance and to treat any injuries sustained during the fall and fall arrest.

A worker should not use a fall arrest system unless there is a competent person and at least one other person on the site who is trained and competent to assist in a rescue if they fall.

7.0 Ladders

Ladders

Section 54 (9) The following requirements must be observed in relation to the use of ladders at work, or to gain access to or exit from a workplace.

- (a) a ladder must be of sound construction and maintained in a safe condition, and
- (b) a ladder must not be used in a manner that endangers the safety of any person; and
- (c) if a portable single ladder or extension ladder is used, the ladder must be –
 - (i) placed so that the horizontal distance between the top support point of the ladder and the foot of the ladder is approximately one quarter of the supported length of the ladder; and
 - (ii) located on a firm footing and effectively secured in position to prevent slipping and sideways movement; and
- (d) no ladder other than a trestle ladder may be used to support planks for a working platform, and any such platform may only be used for light duty work.



Current Samoan law provides that not only must ladders be in sound condition, but they must be used in a safe manner.

Identified International Standards include

AS/NZS 1892 (set): *Portable ladders* including:

- AS/NZS 1892.1:1996: *Portable ladders – Metal*
- AS 1892.2–1992: *Portable ladders – Timber*
- AS/NZS 1892.3:1996: *Portable ladders – Reinforced plastic*
- AS/NZS 1892.5:2000: *Portable ladders – Selection, safe use and care*

Falls from ladders have resulted in a significant number of serious and fatal injuries, even when working at relatively low heights. While ladders are often considered to be the first option when working at heights, they should only be considered after safer alternatives, for example elevating work platforms (EWPs) or scaffolding, have been considered first and found to be not reasonably practicable.

Portable ladders

Extension or single ladders should only be used as a means of access to or exit from a work area or for short duration light work that can be carried out safely from the ladder.

Selecting ladders

Ladders should be selected to suit the work to be carried out. In doing this, you should consider the duration of the work, the physical surroundings of where the work is to be carried out and the prevailing weather conditions.

Depending on the specific task and how it is carried out, step platforms should provide an improved level of fall protection over traditional step or single ladders as they include a small working platform and a partial handrail.

Ladders should have a load rating of at least 120 kg or 150kg and be manufactured for industrial use. Domestic ladders should not be selected for industrial use or for use on construction sites.



Using ladders safely

Workers must be provided with information and training on how to inspect, set up and use ladders safely.

Positioning and setting up ladders

Before setting up a ladder, it should be inspected for visible damage or faults, for example broken rungs, stiles and footings. Faulty or damaged ladders must be removed from service.

When setting up a ladder you should check that:

- the ladder is the correct height for the work to avoid over-reaching or stretching
- locking devices on the ladder are secure, and
- the ladder is not placed so that the weight of the ladder and any person using the ladder is supported by the rungs.

Ladders used at a workplace should be set up on a solid and stable surface, and to prevent the ladder from slipping. Single and extension ladders can be prevented from slipping by:

- ensuring the ladder has non-slip feet
- placing ladders at a slope of 4:1 (the distance between the ladder base and the supporting structure should be about 1 metre for every 4 metres of working ladder height), and
- securing ladders at the top or bottom, or if necessary, at both ends
- Stepladders should be set up in the fully opened position and may require a second person to ‘foot’ the ladder for added stability.

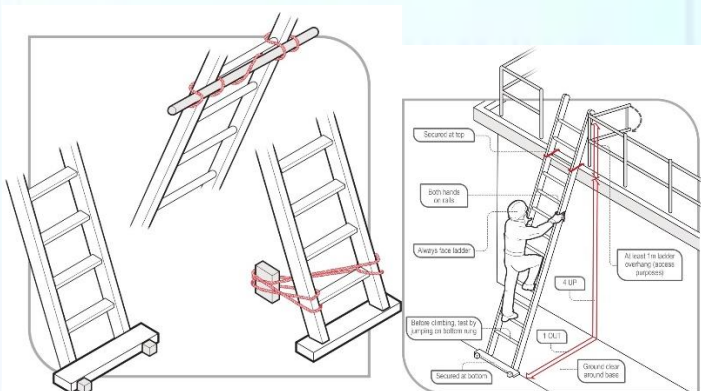

Safe use of ladders

When using a ladder:

- always maintain ‘three points of contact’ as follows:
 - when going up or down a ladder, always have two feet and one hand, or one foot and two hands, on the ladder
 - when working from a ladder, have two feet and one other point of contact with the ladder, such as a hand or thighs leaning against the ladder.
- use a tool belt or side pouch so that materials or tools are not carried in the hands while climbing the ladder
- ensure only light duty work is carried out while on the ladder, where tools can be operated safely with one hand

- make sure that no-one works underneath the ladder
- do not allow anyone else on the ladder at the same time
- do not straddle the ladder, and
- wear slip-resistant footwear.

When using ladders, consider specific industry requirements, it is not safe to:

- use metal or metal reinforced ladders when working on live electrical installations, or
- carry out ‘hot’ work like arc welding or oxy cutting.

Except where additional fall protection equipment is used in conjunction with the ladder, it is not safe to:

- use a stepladder near the edge of an open floor, penetration or beside a railing
- over-reach—the centre of the torso should be within the ladder stiles throughout the work
- use power or hand tools requiring two hands to operate, for example concrete cutting saws and circular saws
- use tools that require a high degree of leverage force which, if released, may cause the user to over-balance or fall from the ladder, for example stillsons or pinch bars
- face away from the ladder when going up or down, or when working from it
- stand on a rung closer than 900 mm to the top of a single or extension ladder, or

stand higher than the second tread below the top plate of a stepladder with the exception of three-rung stepladders, unless working through an overhead opening of the building or structure that provides appropriate additional support above the ladder

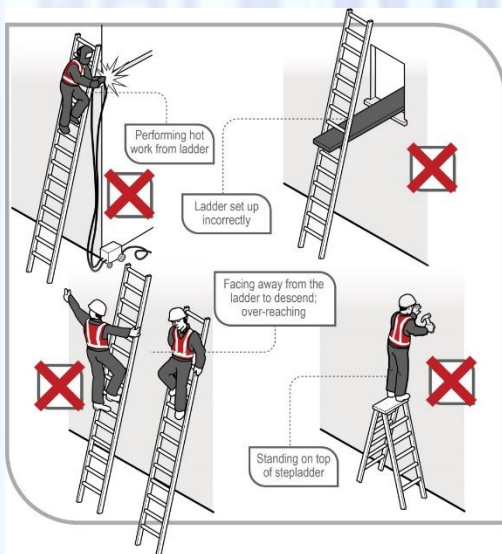

Ladder use in the following situations should only be carried out with additional safety precautions in place:

- in access areas or doorways—if necessary, erect a barrier or lock the door shut
- next to power lines, unless the worker is trained and authorised and the correct ladder for the work is being used
- in very wet or windy conditions, and
- next to traffic areas, unless the working area is barricaded.

Where single or extension ladders are used for entry and exit, you should check that:

- there is a firm, stable work platform, free from obstructions, to step onto from the ladder
- the ladder is securely fixed
- the ladder extends at least 1 metre above the stepping-off point on the working platform, and
- fall protection is provided at the stepping-off point where people access the working platform.

As an alternative to using ladders as a means of access in stairwells, you should consider having the staircase installed as soon as possible.

Further information on the selection, safe use and care of portable ladders is set out in AS/NZS 1892 (set)¹: *Portable ladders*.

The ladder manufacturer's recommendations on safe use should also be followed.

Fixed ladders

Fixed ladders should be installed in accordance with international standards such as, Identified International Standard AS 1657–2018: *Fixed platforms, walkways, stairways and ladders – Design, construction and installation* or similar.

Ladder cages on vertical fixed ladders, that is, over 75 degrees to the horizontal, do not stop a fall but simply funnel a fall and, in some cases, more injuries can occur from striking the protective back guards on the way down. The cages may also hinder rescues. Therefore, fixed ladders with angles exceeding 75 degrees to the horizontal should be fitted with a permanent or temporary fall arrest system using anchorage lines or rails.

The ladder's angle of slope should not be less than 70 degrees to the horizontal and not greater than 75 degrees to the horizontal. In no case should the ladder overhang the person climbing the ladder. If the angle is more than 75 degrees, a safe system of work to prevent falls should be provided, for example a permanent fall arrest system or a full body harness with double lanyard.

A specifically designed rescue procedure should be developed for use in ladder cage situations. Training in rescue procedures should occur before using the fixed ladder.

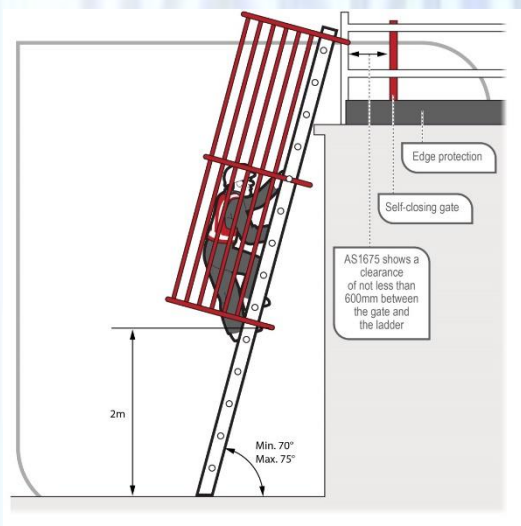

Ladder maintenance

Ladders should be regularly inspected by a competent person in accordance with the manufacturer's recommendations. Ladders with any of the following faults should be replaced or repaired:

- fibreglass stiles cracked, chipped or severely faded with fibres exposed

- timber stiles warped, splintered, cracked or bruised
- metal stiles twisted, bent, kinked, crushed or with cracked welds
- rungs, steps, treads or top plates that are missing, worn, damaged or loose
- tie rods missing, broken or loose
- ropes, braces or brackets that are missing, broken or worn
- timber members that are covered with opaque paint or other treatment that could disguise faults in the timber
- missing, loose, bent or worn fasteners, that is rivets, bolts and pins, and/or
- worn or damaged feet including non-slip material.

8.0 Information, training, instruction and supervision

The employer must ensure that information, training or instruction provided to a worker is suitable and adequate having regard to:

- the nature of the work carried out by the worker
- the nature of the risks associated with the work at the time of the information, training and instruction, and
- the control measures implemented.

Information, training, instruction provided to workers exposed to potential falls from working at any height should include:

- the proper use, wearing, storage and maintenance of PPE
- the hazards and risks associated with work performed at these heights
- how to follow health and safety procedures associated with this work, including the contents of any SWMS, and
- the reasons fall protection measures have been put in place and how to use them properly.

Those supervising the work should also receive training. The amount and type of information, training and instruction required will depend on the nature of the work and the risk involved, as well as the type of fall protection measures used.

The information, training and instruction provided to workers should also include:

- procedures for emergency and rescue
- procedures for reporting fall hazards and incidents
- the correct selection, fitting, use, care, inspection, maintenance and storage of fall arrest and restraint equipment, if this equipment is to be used
- the correct use of tools and equipment used in the work, for example using a tool belt instead of carrying tools, and
- control measures for other potential hazards, for example electrical hazards and crushing or entanglement from the use of plant like elevating work platforms (EWPs).

Workers exposed to a risk of a fall should also be adequately supervised by a competent person, especially if they are undergoing training or are unfamiliar with the working environment.

9.0 Administrative controls

Administrative controls may be used to support other control measures.

If relying on administrative controls, it may be necessary to provide a high level of supervision to ensure that they are being adhered to.

9.1 No go areas

'No go' areas make sure people are not exposed to hazards like falls or being hit by a falling object. They require clear signs warning people not to access the hazardous area. They can be used to highlight the risks of entry to an

area where there is an unguarded hazard, or to areas where work is being carried out overhead and there is a risk of falling objects.

Information and instruction should be provided about no go areas, with supervision to ensure that no unauthorised worker enters the no go area.

Barriers should be used in conjunction with signs to cordon off areas where there is a risk of falling or being hit by falling objects. They should be highly visible and securely fixed to prevent displacement.



9.2 Permit systems

Permit systems allow only competent people trained in the use of relevant control measures to work in an area where there is a hazard. Examples include:

- tagging access points to a scaffold with ‘only licensed scaffolders permitted on an incomplete scaffold’ to restrict unauthorised access during erection and dismantling
- requiring permits for access to areas where restraint systems or fall arrest systems are to be used.

9.3 Organising and sequencing of work

Work should be organised so that people do not interfere with other workers or increase the risk to themselves or others. For example, you can sequence jobs so that different trades are not working above or below each other at the same time. Plan so the work is not carried out for extended periods from a ladder, or so that work at height is minimised in extremely hot or cold weather.

10.0 Emergency procedures for falls

Whenever there are risks from working at height, emergency procedures must be established and first aid equipment provided. Typical injuries from falls can include unconsciousness, blocked airway, impalement, serious head or abdominal injuries and fractures. A person using a fall arrest system could also suffer suspension intolerance as a result of being suspended in a harness after a fall.

You must ensure that workers have access to first aid equipment and facilities for the administration of first aid. You must also ensure that workers are trained to administer first aid or that workers have access to people who are trained in first aid.

The emergency procedures for falls should be incorporated into the emergency plan.

Information about emergency preparedness can be found in the *Guide to Workplace Emergency Facilities and Procedures*.

The table below lists a number of considerations when establishing emergency procedures for falls:

Considerations when establishing emergency procedures for falls

All of the below should be considered in the safe work method statement prior to the work commencing.

Relevant consideration	Questions
Location of the work area	<p>Is the work at height being carried out in a remote or isolated place? How accessible is it in an emergency and how far away is it from medical facilities?</p> <p>Can the rescue of a person after an arrested fall be provided immediately, without relying on emergency services?</p>
Communications	<p>How can workers working at height communicate in an emergency?</p>
Rescue equipment	<p>What kinds of emergencies may arise? The provision of suitable rescue equipment will depend on the nature of the work and the control measures used, for example an emergency rapid response kit with man-made fibre rope, according to AS/NZS 4142.3: 1993: <i>Fibre ropes—Man-made fibre rope for static life rescue lines</i>.</p> <p>Selected rescue equipment should be kept in close proximity to the work area so that it can be used immediately.</p>
Capabilities of rescuers	<p>Are rescuers properly trained, sufficiently fit to carry out their task and capable of using equipment provided for rescue, for example breathing apparatus, lifelines and firefighting equipment?</p> <p>Have emergency procedures been tested to demonstrate that they are effective?</p>
First aid	<p>Is first aid available for injuries associated with falls?</p> <p>Are trained first aid officers available to make proper use of necessary first aid equipment?</p>
Local emergency services—if they are to be relied on for rescue	<p>How will the local emergency services, like ambulance, be notified of an incident? What is the likely response time?</p>

10.1 Suspension intolerance

Suspension intolerance can occur with a fall arrest system when a person has an arrested fall and is suspended in an upright, vertical position. The capacity of the lower legs to store large amounts of blood reduces the return of blood to the heart, slowing the heart rate, which can cause the person to faint. This may lead to renal failure and eventually death, depending on a person's susceptibility. This condition may be worsened by heat and dehydration.

The quick rescue of a person suspended in a harness, as soon as possible, is vital. For this reason, workers should be capable of conducting a rescue of a fallen worker and be familiar with on-site rescue equipment and procedures.

Relevant workers must be trained in the rescue procedures. It is important for workers to be able to recognise the risks of suspension intolerance and act quickly in the rescue of a person.

As time is of the essence in these types of rescues reliance on emergency services is inappropriate. Therefore, employers must ensure there are others at the worksite trained in emergency rescue. The safe work method statement should ensure that consideration is given to rescue procedures.

10.2 Preventing suspension intolerance

To prevent suspension intolerance occurring as a result of an arrested fall, you should ensure that:

- workers never work alone when using a harness as fall protection
- workers use a harness, which allows legs to be kept horizontal

- where the rescue is likely to take more than five minutes the harness and connection point used should allow the suspended worker to raise their legs to near horizontal, or the worker should carry straps to provide footholds
- workers are trained to do the following when they are hanging in their harness after a fall:
 - move their legs in the harness and push against any footholds, where these movements are possible. In some instances, the harness design and any injuries received may prevent this movement
 - move their legs or legs and body to a near horizontal position, where these movements are possible.
 -

10.3 Training for rescues

The training for rescuing workers who have fallen should address the following factors:

- the rescue process should start immediately
- training frequency should take into account the worker's competence and their ability to retain competence through regular exposure to the equipment and skills needed to perform a rescue
- workers should not put themselves at risk during a rescue.

11.0 Steps 4 and 5 of the Hazard Management Process implement, monitor and review

Once risk control measures are decided upon based on hazard identification, risk assessment and where there is a high risk a safe work method statement they must be put into action.

Arrangements are needed to monitor the effectiveness of the control measures and this can be done through;

- Regular workplace inspections
- review of workplace accidents data
- Regular auditing processes

Control measures must be maintained so they remain fit for purpose, suitable for the nature and duration of the work and installed, set up and used correctly.

To allow the chosen control measures to operate effectively, you should develop work procedures on how to correctly install, use and maintain the control measures. The procedures should include a planned program of inspections and maintenance for the control measures. The inspection regime should include details of:

- the equipment to be inspected including its unique identification
- the frequency and type of inspection, for example pre-use checks, detailed inspections
- action to be taken on finding defective equipment
- means of recording the inspections
- training of users, and
- the system of monitoring the inspection regime to verify inspections are carried out appropriately.

The manufacturer or supplier of the equipment should be consulted for product specific requirements. If signs of excessive wear or other defects are found during the inspection the defective equipment must be withdrawn from use

12.0 Designer, manufacturer and supplier obligations for eliminating or minimising the risk of falls at the design stage



Duty of designers, manufacturers and suppliers

A person who designs, manufacturers or supplies any article, or substance or machinery for use at a place of work, shall:

- a) ensure so far as is reasonable that the article, substance or machinery is so designed and constructed and manufactured as to be safe and without risk to health and safety when it is used properly and under relevant information or advice relating to its use which has been provided by the designer, manufacture or supplier
- b) take any steps as are necessary to ensure the provision of adequate information in the English and Samoan language to purchasers and users about the use of which the article, substance or machinery has been designed and about any requirements necessary to ensure that it will be safe and without risk to health and safety when properly used



The design, manufacture or modification of any plant or structure can significantly affect the risk of falls. Careful design and the early consideration of the potential risk of falls can result in the elimination of fall risks.

12.1 Design of workplaces

Safety considerations that may eliminate or minimise risks at the design stage should include:

Buildings and structures

Designers or constructors of buildings or structures must ensure, so far as is reasonable, that workers involved with the **construction**, use or **subsequent maintenance** are not exposed to the risks associated with work at height. Therefore, at the design and planning stage, it is important to consider providing one or more systems designed to prevent falls as part of the building or structure.

- low-level mounting of roof vents
- locating air conditioning and similar plant at ground level
- locating air conditioning units and other roof-mounted plant like satellite dishes away from edges
- specifying non-fragile material for the roof
- using permanent safety mesh
- having safer gutters, for example by installing large volume gutters and downpipes to minimise the need to access the roof for cleaning; locating the gutters at ground level or away from edges; or the removal of gutters altogether, with a smooth transition from the roof to the walls with the gutters at ground level including permanent
- Including permanent anchorage points and hoisting points into structures where maintenance needs to be carried out at height.

Safe **entry to and exit** from work areas, including scaffolding.

Designing permanent guardrails or other forms of edge protection, like parapet walls for permanent fall prevention on roofs for future maintenance requirements, for example in relation to air-conditioning units, sloping building exteriors and windows, to ensure maintenance can be carried out safely. Designing window cleaning bays or gangways into the structure.

Specifying the strength of roof members and other points to which guardrails or anchor points for work positioning systems will be fixed.

Designing the prefabrication of structures on the ground before they are lifted into position, and

Specific safety requirements for particular workers doing subsequent installation, maintenance or repair work.

These groups include:

- people installing and maintaining antennae and satellite dishes
- contractors servicing air-conditioning equipment on the roof, and
- window and gutter cleaners and repairers.

As it is unlikely that all design work on larger projects will be carried out by one designer, consultation, cooperation and coordination should occur between the builder and other designers to ensure the safe interaction of the different design aspects.

Provision of information about remaining risks



Current law requires designers, manufacturers and suppliers, when risks remain in the design work to provide **information** to alert others to the risks. Providing information about safety issues is a key component to ensure proper, adequate and suitable design and installation.

The provision of information to employers by suppliers must be both in English and Samoan.

Safety considerations that may eliminate or minimise risks at the **construction stage** should include:

- reducing the risk for those working at heights, for example installing guardrails to perimeter structural members before erection
- reducing the time spent working at heights by pre-fabricating modules on the ground, before lifting them into position
- sequencing of the work to be carried out at heights
- locating access roads to enable a crane to place building materials in the most accessible location rather than the materials being moved manually
- preparing the ground or floor below the work area—it should be compacted and level to support plant or equipment like cranes and elevating work platforms (EWPs)
- identifying underground services including drainage, for example for the safe setting up of cranes, and
- providing permanent safety mesh.

Planning the site layout during construction of a building or structure

Factors to be considered when planning site layout include:

- preparing firm, level surfaces below work areas for the support of plant and equipment like EWPs or mobile scaffolds
- the site and condition of access roads to enable plant to place material in and pick it up from the most favourable positions, reducing the need for manual handling at height
- the safe access to and exit from work areas and amenities including the provision and placement of stairways, ladders, catwalks, guardrails and barriers, and
- the need for a direct and unobstructed means of escape and rescue in the event of an emergency.

12.2 Design of plant

Safety considerations that may eliminate or minimise risks at the plant design stage could include:

- providing steps and handrails on high vehicles
- incorporating one or more systems designed to prevent falls in silos and overhead conveyors
- ensuring workers who will be maintaining, repairing or cleaning the plant are able to do so safely, including safe access to and exit from the plant, and

- considering the safety of passengers.

Appendix A WORK AT HEIGHTS SELF-ASSESSMENT CHECKLIST

(lisburncastlereagh Uk Gov)

Identification of Work at Height Activities

LIST ACTIVITIES

Are all the work at height activities identified? (Include routine and non-routine activities)	Y	N	
Are the employees / contractors / members of public at risk from work at height identified?	Y	N	Who?
Do your employees work at heights?			List activities
Constantly > 4 hours per day?	Y	N	
Daily?	Y	N	
Weekly?	Y	N	
Monthly, or every few months?	Y	N	
Rarely, once or twice per year?	Y	N	

HAZARD CHECKLIST

During work at height activities are the following hazards controlled?	Comment		
Employee falling from height	Y	N	N/A
Employee falling through a fragile roof	Y	N	N/A
Objects falling on employee's / members of the public	Y	N	N/A
Slipping / collapsing access equipment	Y	N	N/A
Slips / trips on elevated access ways	Y	N	N/A

CONTROL MEASURES CHECKLIST

PLANNING	Comments		
Is working at heights avoided where possible?	Y	N	N/A
Is work at heights properly planned and organised?	Y	N	N/A
Has the work area been surveyed for hazards,	Y	N	N/A

eg overhead power lines, unsuitable ground

conditions, moving machinery parts?

During work at height is there always a competent person present who can suspend work if conditions change, eg weather, traffic, scope of work?

Y N N/A

FRAGILE ROOFS

Are fragile roofs identified, labelled especially where fragility is disguised?

Y N N/A

Are warning signs fixed on the approach to fragile roofs?

Y N N/A

Is unauthorised access to roofs / roof spaces prevented?

Y N N/A

LADDERS/ACCESS EQUIPMENT

Are ladders only used for light work of short duration?

Y N N/A

Are portable ladders inclined at 75° (ratio 1:4) and secured top and bottom?

Y N N/A

Are work platforms capable of supporting workers, equipment, materials, the safe working loads indicated and inspected every six months?

Y N N/A

Are work platforms with edge protection, such as tower scaffolds, cherry pickers, scaffolding always used?

Y N N/A

Are work platforms sufficiently wide to walk on without risk of stumbling or losing balance?

Y N N/A

Are properly constructed safety platforms always fitted if fork lift trucks are used to gain access at heights?

Y N N/A

Are portable ladders, steps and all other access equipment regularly inspected?

Y N N/A

Have workers been trained not to over-reach on

Y N N/A

ladders or work platforms?

Is a written log maintained and access equipment removed from service if broken / damaged?

Y N N/A

Is routine monitoring carried out to ensure that makeshift ladders, or other makeshift access equipment is not being used?

Y N N/A **Comment**

OPEN EDGES

Are open vertical drops identified and properly guarded when open?

Y N N/A

are hand rails present on the open side of staircases?

Y N N/A

Are open edges eg on mezzanine levels provided with appropriate guard rails? (the use of chains, ropes, etc are not suitable)

Y N N/A

Are safe working methods used during delivery / removal of goods to mezzanine areas?

Y N N/A

Are measures always taken to prevent falling objects injuring others as a result of working at heights?

Y N N/A

Is fixed edge protection provided to prevent falls where working at heights cannot be avoided?

Y N N/A

RACKING

Is storage properly planned which discourages climbing racking or pallets to access goods?

Y N N/A

Are adequate provisions in place to allow safe access to stored / displayed goods?

Y N N/A

Are staff trained in safe working methods to access high level racking?

Y N N/A

TRAINING

Have all workers who work at heights been

Y N N/A

assessed as competent or closely supervised by someone who is competent?

PROTECTIVE EQUIPMENT

Where the risk of falls cannot be eliminated are safety harnesses, fall arrest devices or safety nets used as required? (Safety nets protect those working in the space below, fall arrest equipment and safety harnesses require specialist training as well as statutory inspection every 6 months)

Y N N/A

Are anchorage points for safety harnesses and ladders provided, used and regularly inspected?

Y N N/A

If you answered **No** to any of the questions, please note action required below

	Target date
Action point 1	
Action point 2	
Action point 3	
Action point 4	

Appendix B Working at heights safe work method statement (SWMS) template (example Qld Govt, Dept education)

1. Task description: *write the task or job you are doing*

Person responsible for ensuring compliance with this **Equipment required:** *list the equipment and materials you need to complete the task e.g. scaffold, power tools, spill kit.*

SWMS: *write the name of the person responsible for making sure the steps of the SWMS are followed here.* **PPE required:** *list the personal protective equipment workers need to use and wear here e.g. safety glasses, gloves, hard hats, enclosed, non-slip shoes.*

Location of task: *put the name of the work area here*

Date completed:

Key risks (summary): *summarise the key risks for the task here.* **Planning notes:** *list any specific requirements such as mandatory controls, licencing, training requirements, competencies, compliance, and maintenance.*

2. Procedure	3. What are the hazards or risks you have identified?	4. How will the hazards and risks be controlled?	5. Who is responsible for implementing and monitoring these controls?	6. What is the residual risk level?
<i>Write out the task step by step. Use action words since you will be 'doing' each step. e.g.</i>	<i>Include all possible hazards such as:</i>	<i>List all safety controls that must be implemented to complete each of the steps safely e.g.</i>	<i>Identify the person responsible by name for each procedural step</i>	<i>assess</i>
<ul style="list-style-type: none"> • assemble scaffold • complete checklist • secure guardrail 	<ul style="list-style-type: none"> • fall from height/distance of fall • falling objects • manual handling injury-type/severity • electrical hazards • chemical hazards • plant or machinery hazards • site specific hazards • level of training 	<ul style="list-style-type: none"> • barricades or warning signs • PPE • specific duties or responsibilities • storage of materials and equipment • public safety provisions • safety data sheets • housekeeping, maintenance, pre start inspection 		<i>in column 4</i> <i>have been</i> <i>implemented</i>

Prepared by: *name the person(s) who wrote this SWMS*

Review date:

Designation:

Signature:

This SWMS has been developed in consultation and has been read, understood and signed by all workers undertaking the tasks described:

Print names	Signatures	Date

7. **Approved by:** *person in charge of workplace*

Signature:

Position: *e.g. Principal, business services manager*

Date:

Resources: List additional requirements to complete the job e.g.

- Instruction manuals
- Pre-start checklists

References: List any references used e.g.

- Legislation, codes of practice, Australian standards
- Licensing requirements, Compliance certificates, etc.

1. Task Description:

Person responsible for ensuring compliance with this SWMS:
Equipment required:
PPE Required:

Location of task:

Date completed:

Key risks (summary):

Planning notes:

2. Procedure

3. What are the hazards or risks you have identified?

4. How will the hazards and risks be controlled?

5. Who is responsible for implementing and monitoring these controls?

6. What is the residual risk level?

Prepared by:

Review date:

Designation:

Signature:

This SWMS has been developed in consultation and has been read, understood and signed by all workers undertaking the tasks described:

Print names

Signatures

Date

7. Approved by:

Signature:

Position:

Date:

Appendix C—References and other information sources

Australian Standards and Australian/New Zealand Standards

AS 1418.13–1996: *Cranes (including hoists and winches) – Building maintenance units*

AS 1418.17–1996: *Cranes (including hoists and winches) – Design and construction of workboxes*

AS/NZS 1576 (set): *Scaffolding including:*

- AS/NZS 1576.1:2010: *Scaffolding – General requirements*
- AS/NZS 1576.2:2016: *Scaffolding – Couplers and accessories*
- AS/NZS 1576.3:1995: *Prefabricated and tube-and-coupler scaffolding*
- AS/NZS 1576.4:2013: *Scaffolding – Suspended scaffolding*
- AS/NZS 1576.5:1995: *Scaffolding – Prefabricated splitheads and trestles*
- AS/NZS 1576.6:2000: *Scaffolding – Metal tube-and-coupler scaffolding – Deemed to comply with AS/NZS 1576.3*

AS/NZS 1657:2018: *Fixed platforms, walkways, stairways and ladders – Design, construction and installation*

AS/NZS 1891.1:2007: *Industrial fall-arrest systems and devices – Harnesses and ancillary equipment*

AS/NZS 1891.2 Supp 1:2001: *Industrial fall-arrest systems and devices – Horizontal lifeline and rail systems – Prescribed configurations for horizontal lifelines*

AS/NZS 1891.3:1997: *Industrial fall-arrest systems and devices – Fall-arrest devices*

AS/NZS 1891.4:2009: *Industrial fall-arrest systems and devices – Selection, use and maintenance*

AS/NZS 1892 (set): *Portable ladders including:*

- AS/NZS 1892.1:1996: *Portable ladders – Metal*
- AS 1892.2–1992: *Portable ladders – Timber*
- AS/NZS 1892.3:1996: *Portable ladders – Reinforced plastic*
- AS/NZS 1892.5:2000: *Portable ladders – Selection, safe use and care*

AS 2550.16–1997: *Cranes – Safe Use – Mast climbing work platforms*

AS 4142.3–1993: *Fibre ropes – Man-made fibre rope for static life rescue lines*

AS/NZS 4389:2015: *Roof safety mesh*

AS/NZS 4488 (set): *Industrial rope access systems including:*

- AS/NZS 4488.1:1997: *Industrial rope access systems – Specifications*
- AS/NZS 4488.1:1997/Amdt 1:1999: *Industrial rope access systems – Specifications*
- AS/NZS 4488.2:1997: *Industrial rope access systems – Selection, use and maintenance*

AS/NZS 4576:1995: *Guidelines for scaffolding*

AS/NZS 4994 (set): *Temporary edge protection including:*

- AS/NZS 4994.1:2009: *Temporary edge protection – General requirements*
- AS/NZS 4994.2:2009: *Temporary edge protection – Roof edge protection – Installation and dismantling*
- AS/NZS 4994.3:2010: *Temporary edge protection – Installation and dismantling for edges other than roof edges*
- AS/NZS 4994.4:2018: *Temporary edge protection – Perimeter protection screens*

Appendix D, Hazards and Control Combination Examples (New Zealand, Best

Practice for working at Height)

HAZARD	CIRCUMSTANCE	CONTROLS: EACH HAZARD MAY NEED A COMBINATION OF CONTROLS TO ADEQUATELY MINIMISE THE RISK OF INJURY
Falls from height	<ul style="list-style-type: none"> › Access between multiple levels › Advancing edges of in-situ or precast concrete and steel erection › Edges of roofs › Edges of upper-level floors › Ladders › Mechanical plant: EWPs, crane lift platforms, forklifts › Penetrations, openings or hoist areas › Scaffolding: erection and use › Unprotected shafts and excavations 	<p>ELIMINATE</p> <ul style="list-style-type: none"> › Organise work to be carried out on the ground <p>ISOLATE</p> <ul style="list-style-type: none"> › Provide stairs › Provide guardrails, including mid rails › Provide scaffolding › Use elevating work platforms › Cover or fence penetrations and openings › Cover or fence excavations › Cover roof areas with safety mesh before roofs are laid <p>MINIMISE</p> <ul style="list-style-type: none"> › Provide close spacing of roof battens › Provide secure ladder access › Install safety nets › Use restraint (travel restriction) techniques › Use work positioning techniques › Use fall arrest systems › Provide soft landing systems › Use protective footwear that provides a non-slip and flexible grip

Struck by falling objects	<ul style="list-style-type: none"> › Loads are placed on elevated work areas › Overhead crane/lifting operations › Work is to be carried out above other workers 	<ul style="list-style-type: none"> › Assess roof conditions from below <p>ISOLATE</p> <ul style="list-style-type: none"> › Fit toe boards or equivalent protection › Tether tools and equipment › Secure storage of materials › Install catch screens or platforms › Erect a gantry or a protective screen over high-volume/public areas › Fence off lower areas <p>MINIMISE</p> <ul style="list-style-type: none"> › Provide mobile construction plant with a falling object protective structure (FOPS) › Provide warning signage › Provide safety watch person › Wear safety helmets and safety footwear
Trips and slips	<ul style="list-style-type: none"> › Changing levels › Construction debris material/poor housekeeping › Crowded or cluttered work area › Electrical leads › Lapped planks › Sloped work surfaces › Surfaces that are wet/icy, polished, glazed or oily 	<p>ELIMINATE</p> <ul style="list-style-type: none"> › Keep surfaces clean and free of tripping hazards or materials › Keep all work areas tidy and clean, and store materials when not in use › Pull out, screw in, or trim up protruding nails, screws and bolts <p>ISOLATE</p> <ul style="list-style-type: none"> › Isolate any protruding reinforcing steel work <p>MINIMISE</p> <ul style="list-style-type: none"> › Provide adequate work area and good task lighting › Provide non-slip work surfaces
Manual handling	<ul style="list-style-type: none"> › Handling materials which may be caught by the wind › Momentary imbalance leading to sudden movement › Work at height creating awkward body position 	<p>ELIMINATE</p> <ul style="list-style-type: none"> › Use lifting aids to deliver materials <p>ISOLATE</p> <ul style="list-style-type: none"> › Provide an enclosed work area <p>MINIMISE</p> <ul style="list-style-type: none"> › Reduce weight and size of objects › Keep tool belts balanced and weight down › Position work so it is in a neutral position and over-reaching or excessive holding is not required

HAZARD	CIRCUMSTANCE	CONTROLS: EACH HAZARD MAY NEED A COMBINATION OF CONTROLS TO ADEQUATELY MINIMISE THE RISK OF INJURY
Falls through upper level surfaces	<ul style="list-style-type: none"> › Corroded metal roofing › Fragile or brittle surfaces: asbestos cement, cellulose cement, glass, fibreglass, acrylic or other similar moulded or fabricated material › Skylights and roof penetrations 	<p>ISOLATE</p> <ul style="list-style-type: none"> › Use walkways and crawl boards › Cover or guard all brittle and dangerous areas › Work from scaffolding or platforms immediately below brittle surfaces <p>MINIMISE</p> <ul style="list-style-type: none"> › Use mechanical access plant › Use a bump rail or physical barrier to keep all people at least two metres away from brittle areas › Assess roof conditions from below

		› Use protective footwear that provides a non-slip and flexible grip
Electrical shock and arc flash	<p>Working in the proximity of overhead power supply including:</p> <ul style="list-style-type: none"> › MEWPs › scaffold › ladder work › working above or to the side of power lines. <p>Access using insulated work platforms and insulated tools is specialist work, and may only be carried out by workers who have the required competency to industry standards, and in accordance with approved industry procedures.</p>	<p>ELIMINATE Have overhead services transferred to underground before commencing work at height.</p> <p>ISOLATE Overhead conductors are disconnected from service by the power supply company and the work area is confirmed to be safe. Obtain written confirmation from the person who disconnected the power to verify which work areas are isolated from power and which areas are not. Contact the power company to obtain written confirmation of the safe working distance and then plan all work to be conducted from outside of the zone as per the instructions of the power company.</p> <p>MINIMISE Establish a plan that ensures that work can be achieved without likelihood that the minimum approach distances (MAD) (as set out in <i>The New Zealand Electrical Code of Practice for Electrical Safe Distances NZECP34:2001 (NZECP 34)</i>) will be breached. Only allow work in the vicinity of the live lines if this is achievable. Use a safety observer (this is particularly relevant if MEWPs are used, as the operator may become spatially disoriented and the work involves frequent movement or relocation).</p> <p>CAUTION: Work in close proximity of live lines should be completed by workers who have the required electricity industry competency. Access using insulated work platforms and insulated tools is specialist work, and may only be carried out by workers who have the required competency to electricity industry standards, and in accordance with approved industry procedures. Always contact the line owner to seek approval to work close to power lines. Find out what the safe distance is and seek advice on how to work safely. <i>The New Zealand Electrical Code of Practice for Electrical Safe Distances NZECP34:2001 (NZECP 34)</i> is available from the website: www.energysafety.govt.nz</p>

Electrocution	<ul style="list-style-type: none"> › Electrical plant and machinery › Gantry crane 'buzz bars' 	<p>ELIMINATE › Disconnect or de-energise electrical supply</p> <p>ISOLATE › Isolate electrical supply—lock out/tag out › Install insulating barriers, eg, sleeves, wraps, or tiger tails</p> <p>MINIMISE › Plan a safe work process › Provide safety observer</p>
Confined space	<ul style="list-style-type: none"> › Asphyxiation › Explosion › Fall from height › Gas or fumes build up 	<p>ELIMINATE › Work outside of confined space</p> <p>ISOLATE › Refer to <i>Australian Standard AS 2865:2009 Confined Space</i></p> <p>MINIMISE › Refer to <i>Australian Standard AS 2865:2009 Confined Space</i></p>
Excavations, trenches, openings, and shafts	<ul style="list-style-type: none"> › Cave-ins › Engulfment › Fall through 	<p>ELIMINATE › Do not work near excavations, openings, or shafts</p> <p>ISOLATE › Use barriers and keeping safe working distance › securely cover</p> <p>MINIMISE › Refer to the Ministry of Business, Innovation and Employment's <i>Approved Code of Practice for Excavations and Shafts for Foundations</i></p>

Appendix E High risk work licences (for working at height) and classes of high risk work

(based on the Australian WHS Regulation, 2009)

Item	High risk work licence	Description of class of high risk work
<i>Scaffolding work</i>		
1	Basic scaffolding	Scaffolding work involving any of the following: <ul style="list-style-type: none"> (a) modular or pre-fabricated scaffolds; (b) cantilevered materials hoists with a maximum working load of 500 kilograms; (c) ropes; (d) gin wheels; (e) safety nets and static lines; (f) bracket scaffolds (tank and formwork), but excluding scaffolding work involving equipment, loads or tasks listed in item 2(2)(a) to (g) and item 3(2)(a) to (c)
2	Intermediate scaffolding	<ul style="list-style-type: none"> (1) Scaffolding work included in the class of Basic scaffolding; and (2) Scaffolding work involving any of the following: <ul style="list-style-type: none"> (a) cantilevered crane loading platforms; (b) cantilevered scaffolds; (c) spur scaffolds; (d) barrow ramps and sloping platforms; (e) scaffolding associated with perimeter safety screens and shutters; (f) mast climbing work platforms; (g) tube and coupler scaffolds (including tube and coupler covered ways and gantries), but excluding scaffolding work involving equipment, loads or tasks listed in item 3(2)(a) to (c)
3	Advanced scaffolding	<ul style="list-style-type: none"> (1) Scaffolding work included in the class of Intermediate scaffolding; and (2) Scaffolding work involving any of the following: <ul style="list-style-type: none"> (a) cantilevered hoists; (b) hung scaffolds, including scaffolds hung from tubes, wire ropes or chains; (c) suspended scaffolds
<i>Dogging and rigging work</i>		
4	Dogging	Dogging work
5	Basic rigging	<ul style="list-style-type: none"> (1) Dogging work (2) Rigging work involving any of the following: <ul style="list-style-type: none"> (a) structural steel erection; (b) hoists; (c) pre-cast concrete members of a structure; (d) safety nets and static lines;

Item	High risk work licence	Description of class of high risk work
		(e) mast climbing work platforms; (f) perimeter safety screens and shutters; (g) cantilevered crane loading platforms, but excluding rigging work involving equipment, loads or tasks listed in item 6(b) to (f) and item 7(b) to (e)
6	Intermediate rigging	Rigging work involving any of the following: (a) rigging work in the class Basic Rigging; (b) hoists with jibs and self-climbing hoists; (c) cranes, conveyors, dredges and excavators; (d) tilt slabs; (e) demolition of structures or plant; (f) dual lifts, but excluding rigging work involving equipment listed in item 7(b) to (e)
7	Advanced rigging	Rigging work involving any of the following: (a) rigging work in the class Intermediate Rigging; (b) gin poles and shear legs; (c) flying foxes and cable ways; (d) guyed derricks and structures; (e) suspended scaffolds and fabricated hung scaffolds
<i>Crane and hoist operation</i>		
8	Tower crane	Use of a tower crane
9	Self-erecting tower crane	Use of a self-erecting tower crane
10	Derrick crane	Use of a derrick crane
11	Portal boom crane	Use of a portal boom crane
12	Bridge and gantry crane	Use of a bridge crane or gantry crane that is: (a) controlled from a permanent cabin or control station on the crane; or (b) remotely controlled and having more than 3 powered operations, including the application of load estimation and slinging techniques to move a load
13	Vehicle loading crane	Use of a vehicle loading crane with a capacity of 10 metre tonnes or more, including the application of load estimation and slinging techniques to move a load
14	Non-slewing mobile crane	Use of a non-slewing mobile crane with a capacity exceeding 3 tonnes

Item	High risk work licence	Description of class of high risk work
15	Slewing mobile crane—with a capacity up to 20 tonnes	Use of a slewing mobile crane with a capacity of 20 tonnes or less Use of a vehicle loading crane with a capacity of 10 metre tonnes or more, excluding the application of load estimation and slinging techniques to move a load Use of a non-slewing mobile crane with a capacity exceeding 3 tonnes Use of a reach stacker
16	Slewing mobile crane—with a capacity up to 60 tonnes	Use of a slewing mobile crane with a capacity of 60 tonnes or less Use of a vehicle loading crane with a capacity of 10 metre tonnes or more, excluding the application of load estimation and slinging techniques to move a load Use of a non-slewing mobile crane with a capacity exceeding 3 tonnes Use of a reach stacker
17	Slewing mobile crane—with a capacity up to 100 tonnes	Use of a slewing mobile crane with a capacity of 100 tonnes or less Use of a vehicle loading crane with a capacity of 10 metre tonnes or more, excluding the application of load estimation and slinging techniques to move a load Use of a non-slewing mobile crane with a capacity exceeding 3 tonnes Use of a reach stacker
18	Slewing mobile crane—with a capacity over 100 tonnes	Use of a slewing mobile crane with a capacity exceeding 100 tonnes Use of a vehicle loading crane with a capacity of 10 metre tonnes or more, excluding the application of load estimation and slinging techniques to move a load Use of a non-slewing mobile crane with a capacity exceeding 3 tonnes Use of a reach stacker
19	Materials hoist	Use of a materials hoist
20	Personnel and materials hoist	Use of a personnel and materials hoist Use of a materials hoist
21	Boom-type elevating work platform	Use of a boom-type elevating work platform where the length of the boom is 11 metres or more
22	Concrete placing boom	Use of a concrete placing boom
Reach stackers		
23	Reach stacker	Operation of a reach stacker of greater than 3 tonnes capacity that incorporates an attachment for lifting, moving and travelling with a shipping container, but does not include a portainer crane
Forklift operation		
24	Forklift truck	Use of a forklift truck other than an order-picking forklift truck
25	Order-picking forklift truck	Use of an order-picking forklift truck

Purpose of this Schedule

This Schedule sets out the **qualifications for high risk work licences.**

Item	Licence Class	VET course
1	Basic scaffolding	Licence to erect, alter and dismantle scaffolding basic level
2	Intermediate scaffolding	Licence to erect, alter and dismantle scaffolding basic level; and Licence to erect, alter and dismantle scaffolding intermediate level
3	Advanced scaffolding	Licence to erect, alter and dismantle scaffolding basic level; and Licence to erect, alter and dismantle scaffolding intermediate level; and Licence to erect, alter and dismantle scaffolding advanced level
4	Dogging	Licence to perform dogging
5	Basic rigging	Licence to perform dogging; and Licence to perform rigging basic level
6	Intermediate rigging	Licence to perform dogging; and Licence to perform rigging basic level; and Licence to perform rigging intermediate level
7	Advanced rigging	Licence to perform dogging; and Licence to perform rigging basic level; and Licence to perform rigging intermediate level; and Licence to perform rigging advanced level
8	Tower crane	Licence to operate a tower crane
9	Self-erecting tower crane	Licence to operate a self-erecting tower crane
10	Derrick crane	Licence to operate a derrick crane
11	Portal boom crane	Licence to operate a portal boom crane
12	Bridge and gantry crane	Licence to operate a bridge and gantry crane
13	Vehicle loading crane	Licence to operate a vehicle loading crane (capacity 10 metre tonnes and above)
14	Non-slewing mobile crane	Licence to operate a non-slewing mobile crane (greater than 3 tonnes capacity)
15	Slewing mobile crane— with a capacity up to 20 tonnes	Licence to operate a slewing mobile crane (up to 20 tonnes)
16	Slewing mobile crane— with a capacity up to 60 tonnes	Licence to operate a slewing mobile crane (up to 60 tonnes)
17	Slewing mobile crane— with a capacity up to 100 tonnes	Licence to operate a slewing mobile crane (up to 100 tonnes)
18	Slewing mobile crane— with a capacity over 100 tonnes	Licence to operate a slewing mobile crane (over 100 tonnes)

Item	Licence Class	VET course
19	Materials hoist	Licence to operate a materials hoist
20	Personnel and materials hoist	Licence to operate a personnel and materials hoist
21	Boom-type elevating work platform	Licence to operate a boom-type elevating work platform (boom length 11 metres or more)
22	Concrete placing boom	Licence to operate a concrete placing boom
23	Reach stacker	Licence to operate a reach stacker of greater than 3 tonnes capacity
24	Forklift truck	Licence to operate a forklift truck
25	Order-picking forklift truck	Licence to operate an order picking forklift truck



STAYING
SAFE WHILE
WORKING
AT HEIGHTS



CONTACT INFORMATION

For further information about Managing the risk of falls at height in the workplace and OSH
Compliance contact MCIL/OSH Unit

P.O. Box 862, Apia, SAMOA | Telephone: (685) 20441/ 20442/ 20882 | Facsimile: (685) 20443 |
Email: mpal@mcil.gov.ws. Level 4, ACC House, Apia | Website: www.mcil.gov.ws